

**Manufacturer:**

OilQuickAmericas  
155 Main Street  
Superior, WI 54880  
Phone: 262.607.8425  
Fax: 715.395.3703

E-mail: [info@oilquickamericas.com](mailto:info@oilquickamericas.com)  
Web: [www.oilquickamericas.com](http://www.oilquickamericas.com)

**When ordering spare parts:**

- Include the part number, description and desired quantities.
- Include your complete address.
- Specify how the parts are to be delivered.



## TABLE OF CONTENTS

### OQC90-R68

#### 1.0 - ROTATOR KIT

<b>1.1 - 07013-0045 (01) - QUICK COUPLER ROTATOR</b> .....	<b>4</b>
<b>1.2 - 07012-7529 - ROTATOR</b> .....	<b>6</b>
1.2.1 - 07009-1131 - MOTOR ASSEMBLY (1450 PSI) .....	9
1.2.1.1 - 07009-1132 - VALVE MANIFOLD .....	10
1.2.1.2 - 07013-1151 - MOTOR & PINION .....	11
1.2.2 - 07012-2957 (04) - ACCUMULATOR OPTION KIT .....	12
1.2.3 - 07012-7527 - HYDRAULIC SWIVEL ASSY .....	14
<b>1.3 - 07013-0044 (01) - ELECTRICAL INSTALLATION</b> .....	<b>16</b>
1.3.1 - 07013-0044 (01) - ELECTRICAL INSTALLATION .....	16
<b>1.4 - 07012-7465 - ELECTRICAL SCHEMATIC</b> .....	<b>18</b>

#### 2.0 - COUPLER

2.1 - OQEO6068 - OQC90 SS COUPLER CHASSIS KIT .....	20
2.2 - OQE07457 - ASSY H-CYLINDER 2.0 OQC90 .....	22
2.3 - OQC90 - GUARD .....	24
2.4 - OQ4126375 - ELECTRICAL COUPLING 100A 1/2" .....	26
2.5 - REAR SENSOR .....	27

#### 3.0 - ADAPTER PLATES

3.1 - OQ5113070 - HYDRAULIC ADAPTER BRACKET .....	28
3.2 - OQ5113069 - MAGNET ADAPTER BRACKET .....	29

# 1.0 ROTATOR KIT

## 1.1 - 07013-0045 (01) - QUICK COUPLER ROTATOR KIT

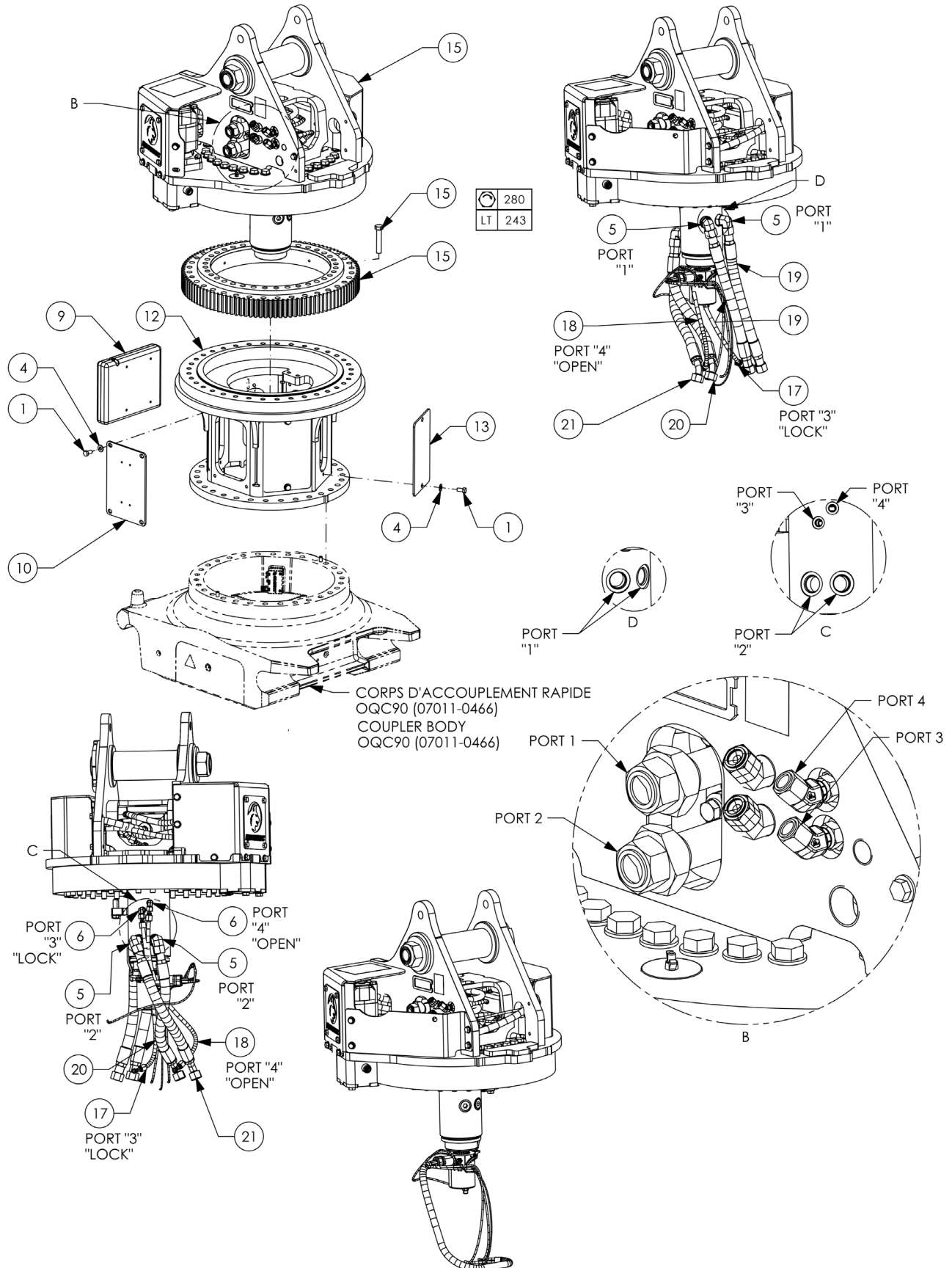

ITEM	PART NO.	NAME	QTY	UOM
1	008-0239	BOLT, 1/2-13 UNC x 1"lg. Gr.8 ZINC	16	EA
2	008-0262	BOLT, 5/8-11 UNC x 2 1/2"lg. Gr.8	4	EA
3	010-8447	LOCK NUT, 5/8-11 UNC	4	EA
4	012-0025	FLAT WASHER, 1/2"dia.	16	EA
5	030-0176	HYDRAULIC FITTING	4	EA
6	030-0561	HYDRAULIC FITTING	2	EA
7	052-0688	BLUE NYLON TIE WRAP	2	EA
8	052-0690	YELLOW NYLON TIE WRAP	1	EA
9	052-1227	MANUAL PACK	1	EA
10	07011-0425	PLATE	2	EA
11	07011-0428	SHIPPING PALLET	1	EA
12	07011-4587	SPACER ASS'Y	1	EA
13	07012-1515	PLATE	4	EA
14	07012-7465	ELECTRICAL SCHEMATIC	1	EA
15	07012-7529	ROTATOR	1	EA
16	07013-0044	ELECTRICAL INSTALLATION	1	EA
17	099-7548	HOSE 24 1/2" (CUT LENGTH)	1	EA
18	099-7549	HOSE 25 1/2" (CUT LENGTH)	1	EA
19	099-8106	HOSE 19" (CUT LENGTH)	2	EA
20	099-8107	HOSE 19" (CUT LENGTH)	1	EA
21	099-8108	HOSE 20" (CUT LENGTH)	1	EA
22	146-2355	"RT-...HFE0...-OQC.." SERVICE MANUAL	1	EA

Comments for Page: 07013-0045 (01) QUICK COUPLER ROTATOR KIT

(#15 7012-7529) Use a torque wrench. Lubricated torque values in ft-lb. LT= Loctite

# 1.0 ROTATOR KIT

## 1.2 - 07012-7529 - ROTATOR

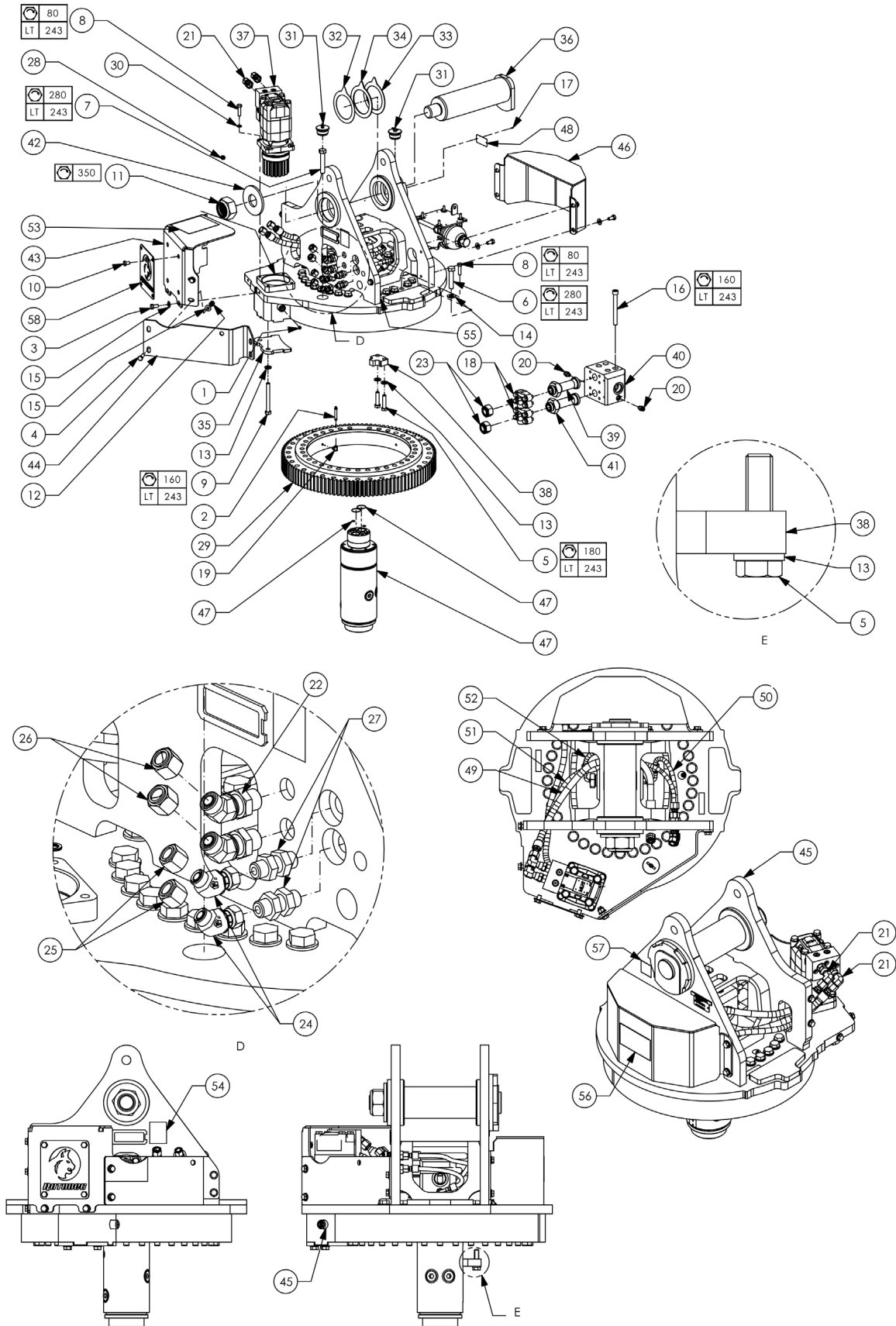

ITEM	PART NO.	NAME	QTY	UOM
1	001-0001	GREASE FITTING, 1/8 NPT	1	EA
2	001-0015	GREASE FITTING, 1/8 NPT	2	EA
3	008-0239	BOLT, 1/2-13 UNC x 1"lg. Gr.8 ZINC	7	EA
4	008-0241	BOLT, 1/2-13 UNC x 1 1/2"lg. Gr.8 ZINC	2	EA
5	008-0262	BOLT, 5/8-11 UNC x 2 1/2"lg. Gr.8	2	EA
6	008-0277	BOLT, 3/4-10 UNC x 3 1/2"lg. Gr.8 ZINC	32	EA
7	008-0278	BOLT, 3/4-10 UNC x 4"lg. Gr.8 ZINC	36	EA
8	008-4527	BOLT, 1/2-3 UNC x 1 3/4"lg. Gr.8	10	EA
9	008-4810	BOLT, 5/8-11 UNC x 5 1/2"lg. Gr.8 ZINC	2	EA
10	008-6133	BOLT, 1/2-13 UNC x 3/4"lg. Gr.8 ZINC	4	EA
11	010-0029	LOCK NUT	1	EA
12	010-4433	NYLON LOCK NUT, 1/2-13 UNC Gr.8 ZINC	2	EA
13	012-0003	FLAT WASHER	4	EA
14	012-0012	FLAT WASHER, 3/4"dia. Gr.8	32	EA
15	012-0025	FLAT WASHER, 1/2"dia.	11	EA
16	017-0254	HEX. SOCKET HEAD CAP SCREW, 5/8-11 UNC x 6"lg. Gr.8	4	EA
17	020-7759	FALSE SCREW, 4 x 1/4"lg.	2	EA
18	025-0003	FLANGE	2	EA
19	026-1036	90 M/F ADAPTOR, 1/8 NPT x 1/8 NPT	2	EA
20	030-0323	HYDRAULIC FITTING	2	EA
21	030-0425	HYDRAULIC FITTING	2	EA
22	030-0487	HYDRAULIC FITTING	2	EA
23	030-0510	HYDRAULIC FITTING	2	EA
24	030-0575	HYDRAULIC FITTING	2	EA
25	030-8541	HYDRAULIC FITTING	2	EA
26	030-8552	ORFS PLUG 10	2	EA
27	030-8823	O'RING FACE SEAL BH UNION, 8 ORFSM x 8 ORFSM	2	EA
28	041-1729	O-RING	1	EA
29	048-0090	SLEWING RING	1	EA
30	052-0138	LOCK WASHER, 1/2"dia	4	EA
31	052-0657	SEALING PLUG, 2"dia.	2	EA
32	07003-1427	SHIM (.030)	2	EA
33	07003-1428	SHIM (.075)	2	EA

ITEM	PART NO.	NAME	QTY	UOM
34	07003-1429	SHIM (.120)	1	EA
35	07008-7138	COVER	1	EA
36	07008-7160	PIN	1	EA
37	07009-1131	MOTOR ASS'Y	1	EA
38	07009-2624	HYDRAULIC SWIVEL LOCK	1	EA
39	07010-3055	HYDRAULIC FITTING	1	EA
40	07010-3714	HYDRAULIC SWIVEL HEAD	1	EA
41	07010-5816	HYDRAULIC FITTING	1	EA
42	07010-5840	WASHER	1	EA
43	07011-5779	MOTOR GUARD	1	EA
44	07011-5781	HOSE GUARD	1	EA
45	07011-5785	ROTATOR BASE ASS'Y	1	EA
46	07012-2957	ACCUMULATOR OPTION KIT	1	EA
47	07012-7527	HYDRAULIC SWIVEL ASS'Y	1	EA
48	07012-7538	HJ3 NAME PLATE	1	EA
49	099-7529	HOSE 34" (CUT LENGTH)	1	EA
50	099-7538	HOSE 20" (CUT LENGTH)	1	EA
51	099-7539	HOSE 33" (CUT LENGTH)	1	EA
52	099-7610	HOSE 21" (CUT LENGTH)	1	EA
53	146-0219	GREASE ,LABEL	1	EA
54	146-0239	DANGER, LABEL	1	EA
55	146-0739	STRAIGHT GREASE CHROME ARROW, LABEL	2	EA
56	146-1148	ELECTRIC SHOCK HAZARD, LABEL	1	EA
57	146-3567	CAUTION LABEL	1	EA
58	509-0005	LOGO	1	EA
59	07010-6063	SEAL KIT	1	EA
60	146-2355	"RT-...HFE0...-OQC.." SERVICE MANUAL	1	EA

Comments for Page: 07012-7529 (04) ROTATOR

(#5 008-0262),(#6 008-0277),(#7 008-0278),(#8 008-4527),(#9 008-4810),(#16 017-0254) Use a torque wrench. Lubricated torque values in ft-lb. LT= Loctite  
 (#11 010-0029) Use a torque wrench. Lubricated torque values in ft-lb.

1.2.1 - 07009-1131 - MOTOR ASSEMBLY (1450 PSI)

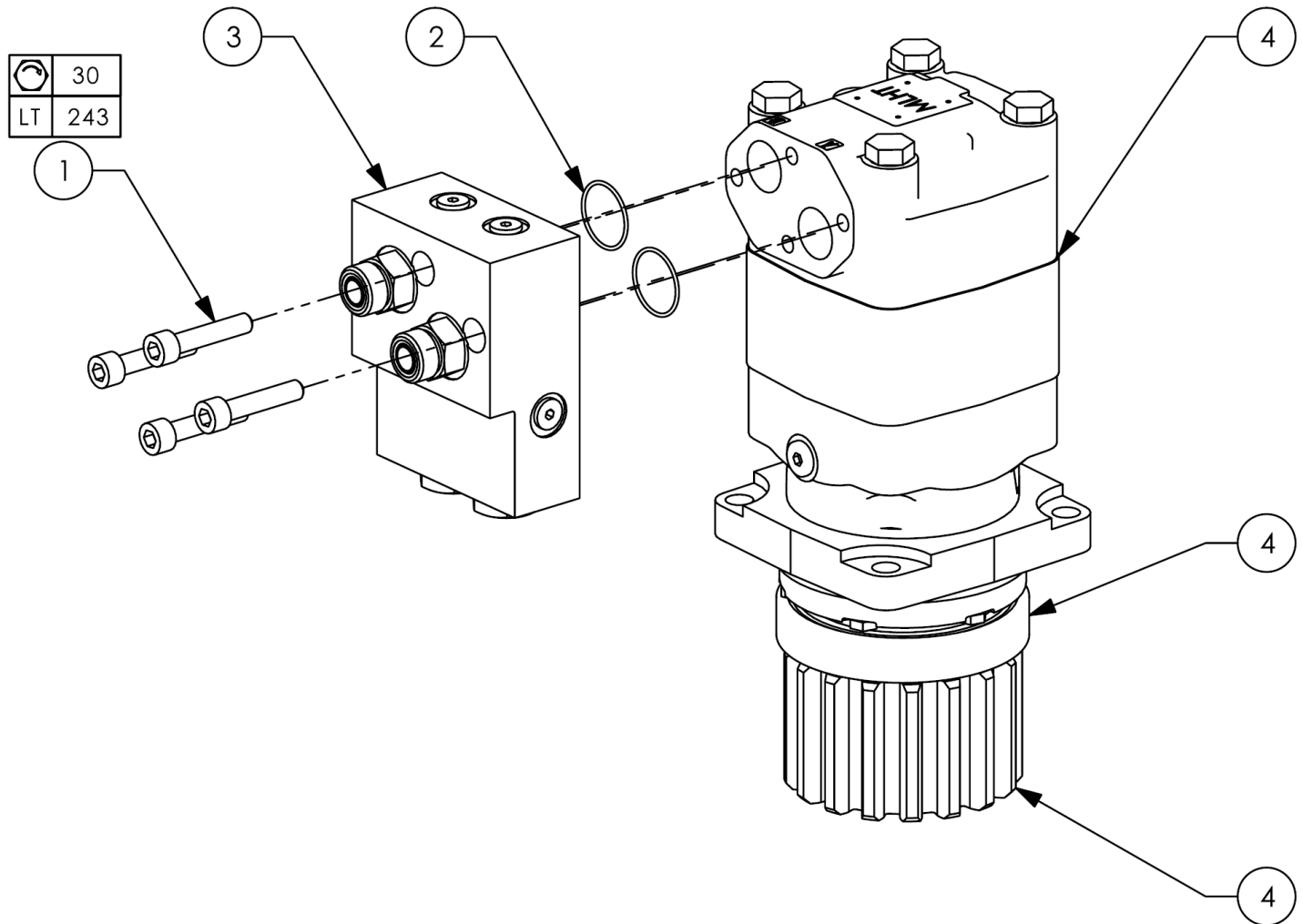

ITEM	PART NO.	NAME	QTY	UOM
1	017-0190	HEX. SOCKET HEAD CAP SCREW, M10 x 1.5 x 50 Gr. 8.8	4	EA
2	041-0103	SEAL	2	EA
3	07009-1132	VALVE MANIFOLD	1	EA
4	07013-1151	MOTOR & PINION	1	EA

Comments for Page: 07009-1131 (01) MOTOR ASS'Y

(#1 017-0190) Use a torque wrench. Lubricated torque values in ft-lb. LT= Loctite

### 1.2.1.1 - 07009-1132 - VALVE MANIFOLD

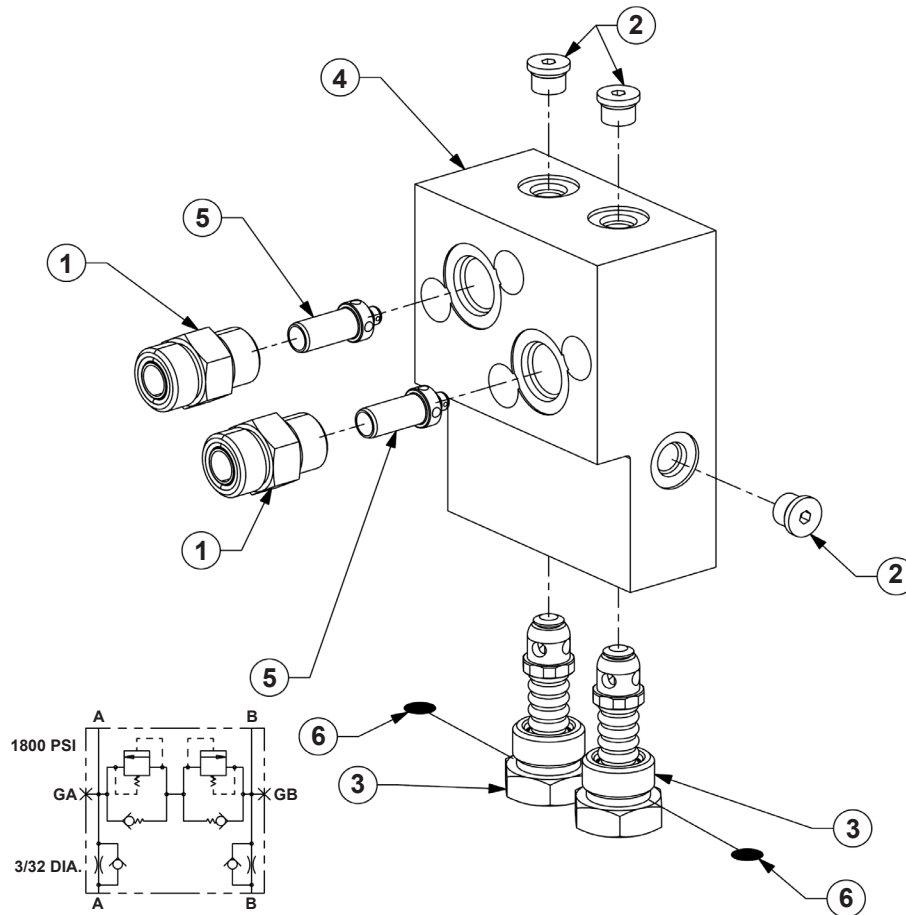

ITEM	PART NO.	NAME	QTY	UOM
1	030-0185	ORB MALE CONNECTOR, ORFS 10 x MALE SAE 10	2	EA
2	030-0228	HYDRAULIC FITTING	3	EA
3	07000-2297	RELIEF CARTRIDGE VALVE ASS'Y	2	EA
4	07001-7374	HYDRAULIC MANIFOLD	1	EA
5	638-0010	RESTRICTOR	2	EA
6	041-3741	O-RING	2	EA

Comments for Page: 07009-1132 VALVE MANIFOLD

(#3 07000-2297) Seal kit #6

### 1.2.1.2 - 07013-1151 - MOTOR & PINION

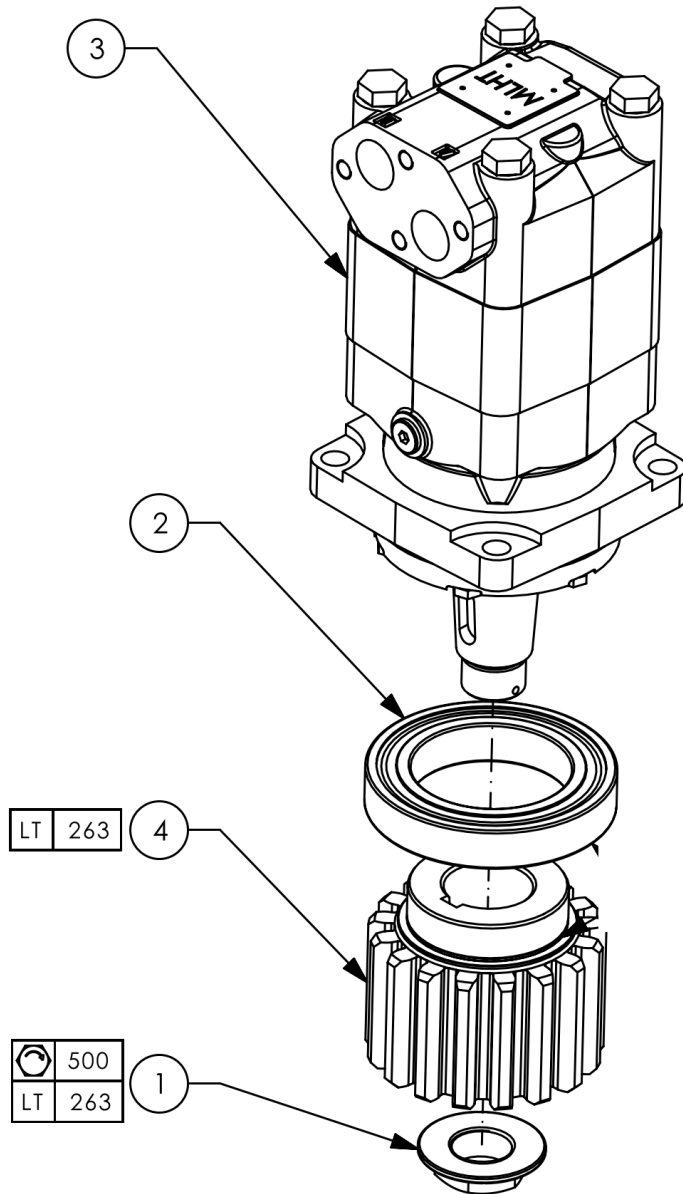

ITEM	PART NO.	NAME	QTY	UOM
1	011-0349	NUT, 1 1/4 UNF	1	EA
2	048-0112	BALL BEARING	1	EA
3	061-0244	HYDRAULIC MOTOR	1	EA
4	07001-7357	PINION	1	EA
5	061-0245	MOTOR SEAL KIT	1	EA

Comments for Page: 07013-1151 MOTOR & PINION

(#1 011-0349) Use a torque wrench. Lubricated torque values in ft-lb. LT= Loctite

(#4 07001-7357) Use "Loctite" LT= Loctite

(#3 061-0244) Seal kit #5

1.2.2 - 07012-2957 (04) - ACCUMULATOR OPTION KIT

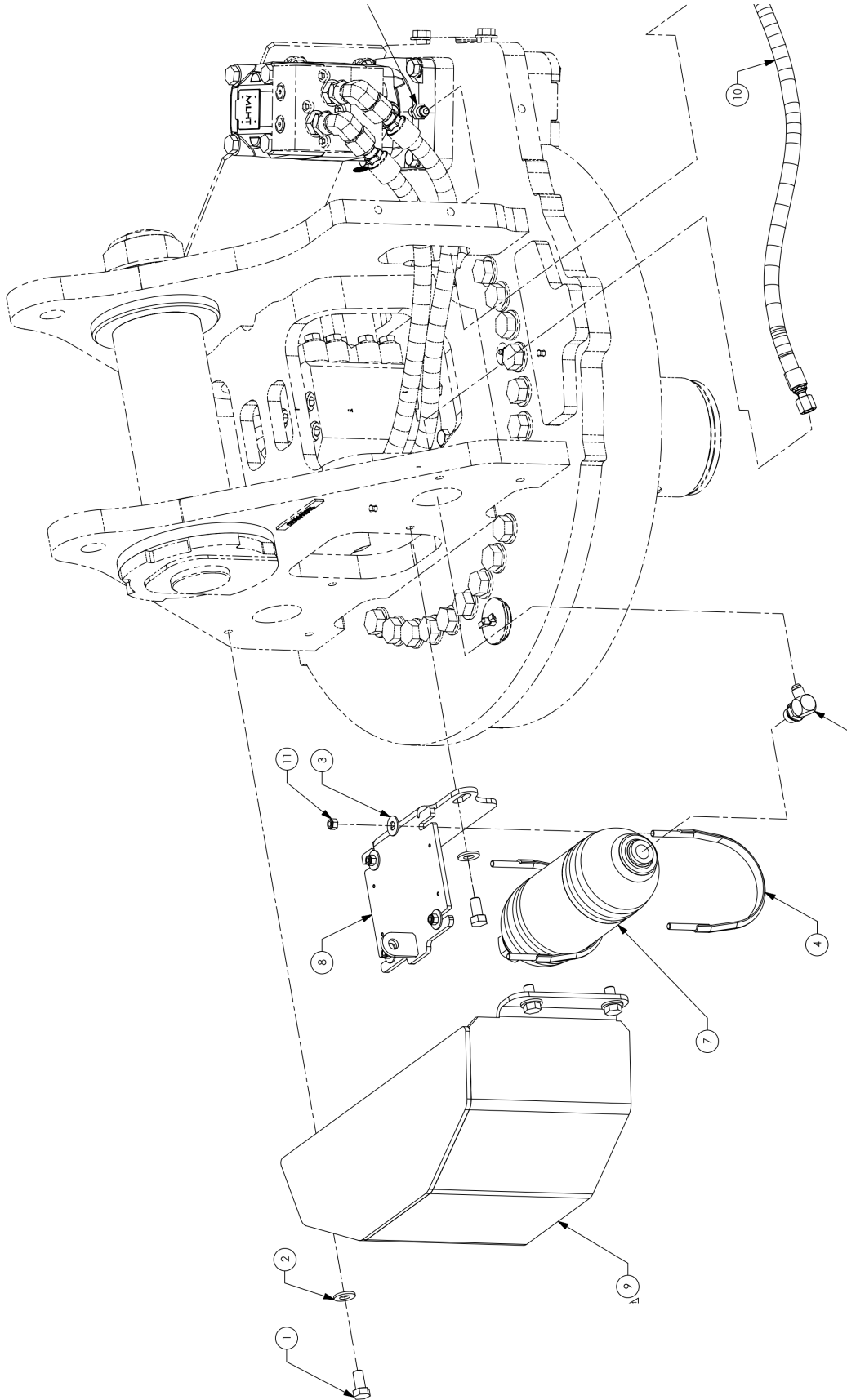

ITEM	PART NO.	NAME	QTY	UOM
1	008-0239	BOLT, 1/2-13 UNC x 1"lg. Gr.8 ZINC	6	EA
2	012-0025	FLAT WASHER, 1/2" dia.	6	EA
3	012-0352	FLAT WASHER, 3/8 x 1.00"	4	EA
4	018-0041	FIXATION CLAMP	2	EA
5	030-1425	90° ADJUSTABLE ADAPTOR, MJIC 6 x 8 ORB	1	EA
6	030-7901	STRAIGHT MALE ADAPTOR, MJIC 6 x M BSPP 4	1	EA
7	07001-0536	ACCUMULATOR CHARGE	1	EA
8	07012-3072	BRACKET ASS'Y	1	EA
9	07013-3362	GUARD ASS'Y	1	EA
10	099-7688	HOSE 22" (CUT LENGTH)	1	EA
11	127-7299	NYLON LOCK NUT, M8 x 1.25"lg. CL8.8	4	EA

# 1.0 - ROTATOR KIT

## 1.2 - 07012-3367 - ROTATOR

### 1.2.3 - 07012-7527 - HYDRAULIC SWIVEL ASSY

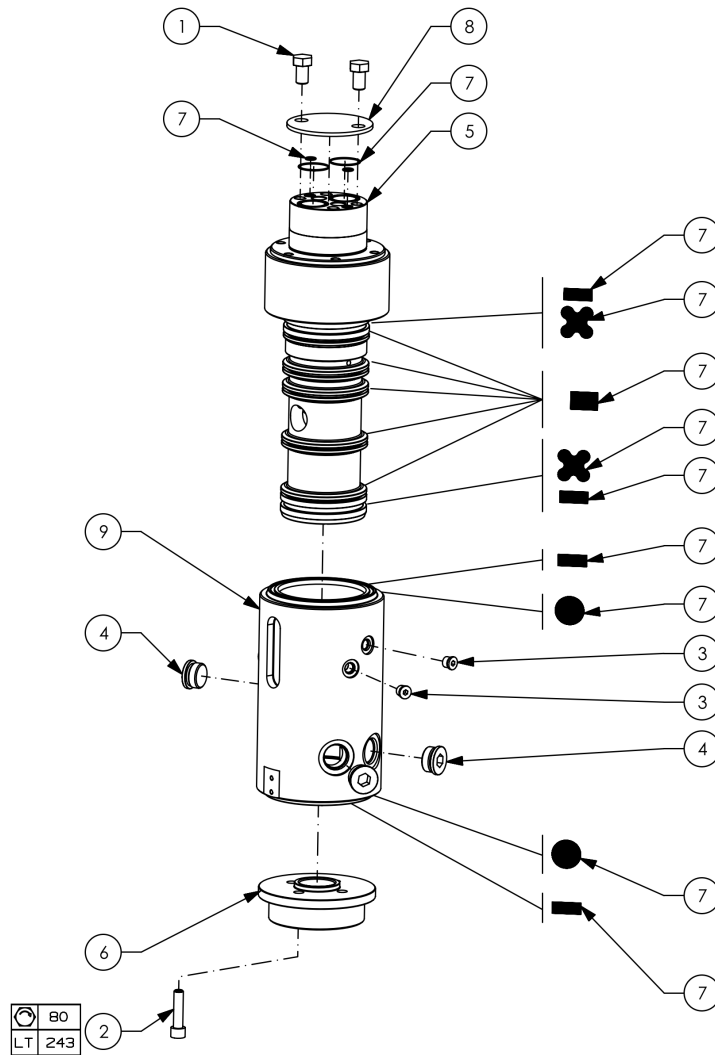

ITEM	PART NO.	NAME	QTY	UOM
1	008-0258	BOLT, 5/8-11 UNC x 1"lg. Gr.8 ZINC	2	EA
2	017-0652	HEX. SOCKET HEAD CAP SCREW, 1/2-13 UNC x 2"lg. Gr.8 ZINC	4	EA
3	030-7727	MALE ORB PLUG	2	EA
4	030-8958	PLUG MALE, 16 ORB	4	EA
5	07010-3683	HYDRAULIC SWIVEL SHAFT	1	EA
6	07010-5371	END PLATE	1	EA
7	07010-5853	SEAL KIT	1	EA
8	07010-8288	SWIVEL COVER	1	EA
9	07011-0418	HYDRAULIC SWIVEL BARREL	1	EA

Comments for Page: 07012-7527 HYDRAULIC SWIVEL ASSY

(#2 017-0652) Use a torque wrench. Lubricated torque values in ft-lb. LT= Loctite





ITEM	PART NO.	NAME	QTY	UOM
1	008-0303	BOLT, 5/16-18 UNC X 5/8"LG. GR.8	4	EA
2	009-0328	NUT, 1/4-20 UNC GR.8	1	EA
3	012-0351	FLAT WASHER, 5/16"DIA.	4	EA
4	017-0160	HEX. SOCKET HEAD CAP SCREW, 8-32 UNC x 5/8"lg. Gr.8 ZINC	4	EA
5	017-6146	HEX. SOCKET HEAD CAP SCREW, 1/4-20 UNC x 1/2"lg. ZINC	4	EA
6	020-0740	MECH. ROUND HEAD SQUARE SOCKET, 8-32 UNC x 1"lg.	1	EA
7	020-9618	NYLON LOCK NUT, 8-32 UNC	1	EA
8	043-0006	GASKET SEAL	1	EA
9	052-0015	CABLE GLAND	2	EA
10	052-0047	CABLE GLAND NUT	1	EA
11	052-2119	HEAT SHRINK TUBING DUAL WALL	1	FT
12	052-2960	CABLE GLAND REDUCER, 3/4 NPT	2	EA
13	052-2967	CABLE GLAND, 1 1/4 NPT (METAL)	2	EA
14	052-3693	SPLICE KIT	2	EA
15	052-3703	MULTI-CABLE GLAND SEALING GROMMET	2	EA
16	052-3781	ADAPTER M12 CIRCULAR CONNECTOR	1	EA
17	052-3782	4 PIN M12 CONNECTOR CABLE	1	EA
18	052-3792	SOLDER SLEEVE (.105)	4	EA
19	052-3800	ELECTRIC SLIPRING	1	EA
20	052-9188	NYLON TIE WRAP	1	EA
21	052-9609	CABLE GLAND NUT	1	EA
22	07001-6468	ADAPTOR	2	EA
23	07010-5438	ELECTRIC SWIVEL LOCK	1	EA
24	07012-3119	JUNCTION BOX	1	EA
A,F,H	052-8733	PROTECTIVE NYLON SLEEVE, 14"lg. dia. 3/4"		FT
B-C	052-8094	WIRE PROTECTOR, 1/2"ID		FT
D	052-0162	HEAT SHRINK TUBING 1/2"		FT
E	052-8614	HEATSHRINK TUBING, 3/8"		FT
G	052-8094	WIRE PROTECTOR, 1/2"ID		FT
J	052-0021	JUNCTION TERMINAL BLOCK		FT

Comments for Page: 07013-0044 (01) ELECTRICAL INSTALLATION

(#1 008-0303) Use ""Loctite"" LT= Loctite

# 1.0 - ROTATOR KIT

## 1.4 - 07012-7465 - ELECTRICAL SCHEMATIC

### OQC90 COUPLERS

#### MACHINE SIDE

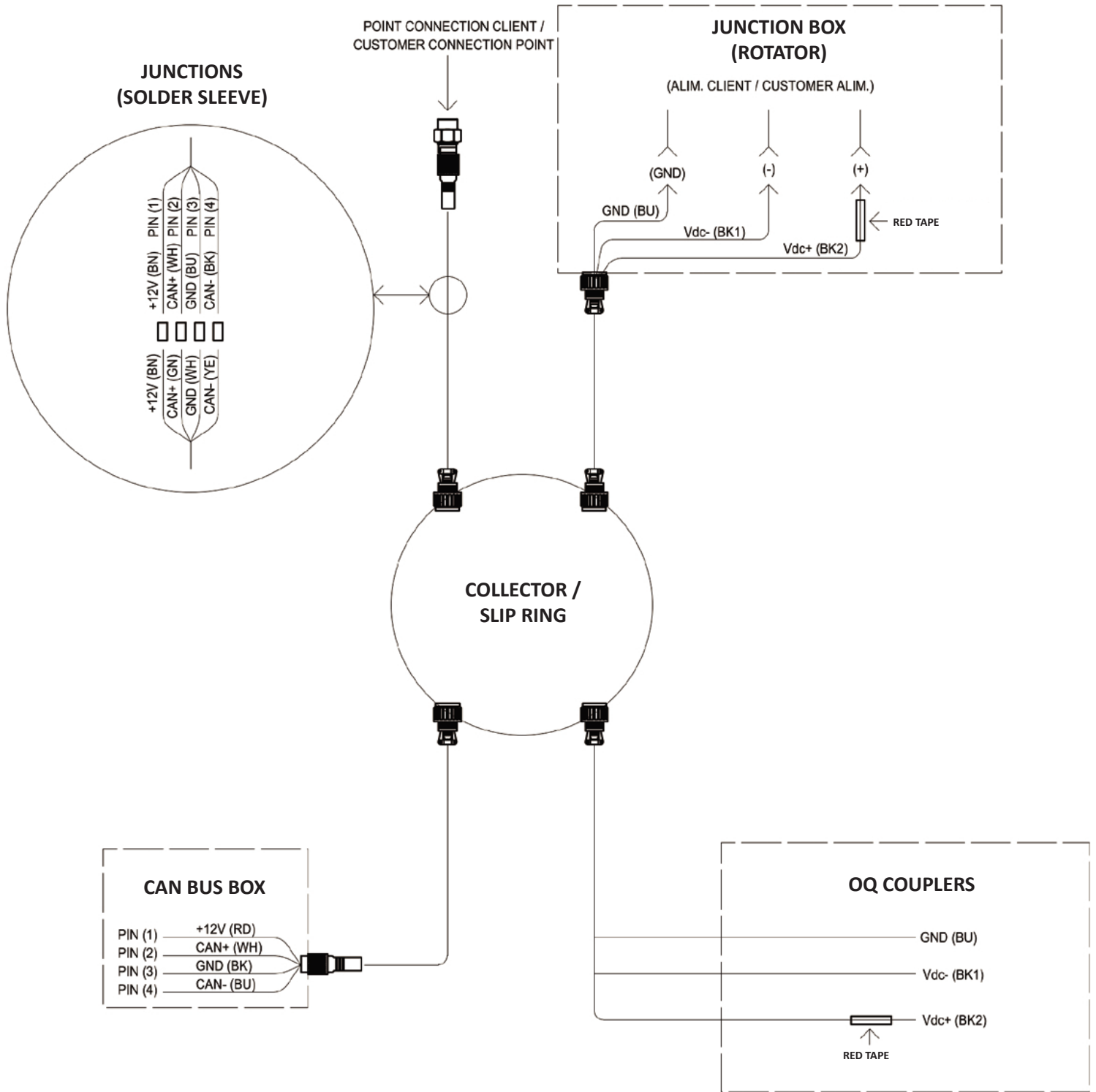

#### OIL QUICK SIDE



## 2.0 - COUPLER

### 2.1 - OQE06068 - OQC90 SS COUPLER CHASSIS KIT

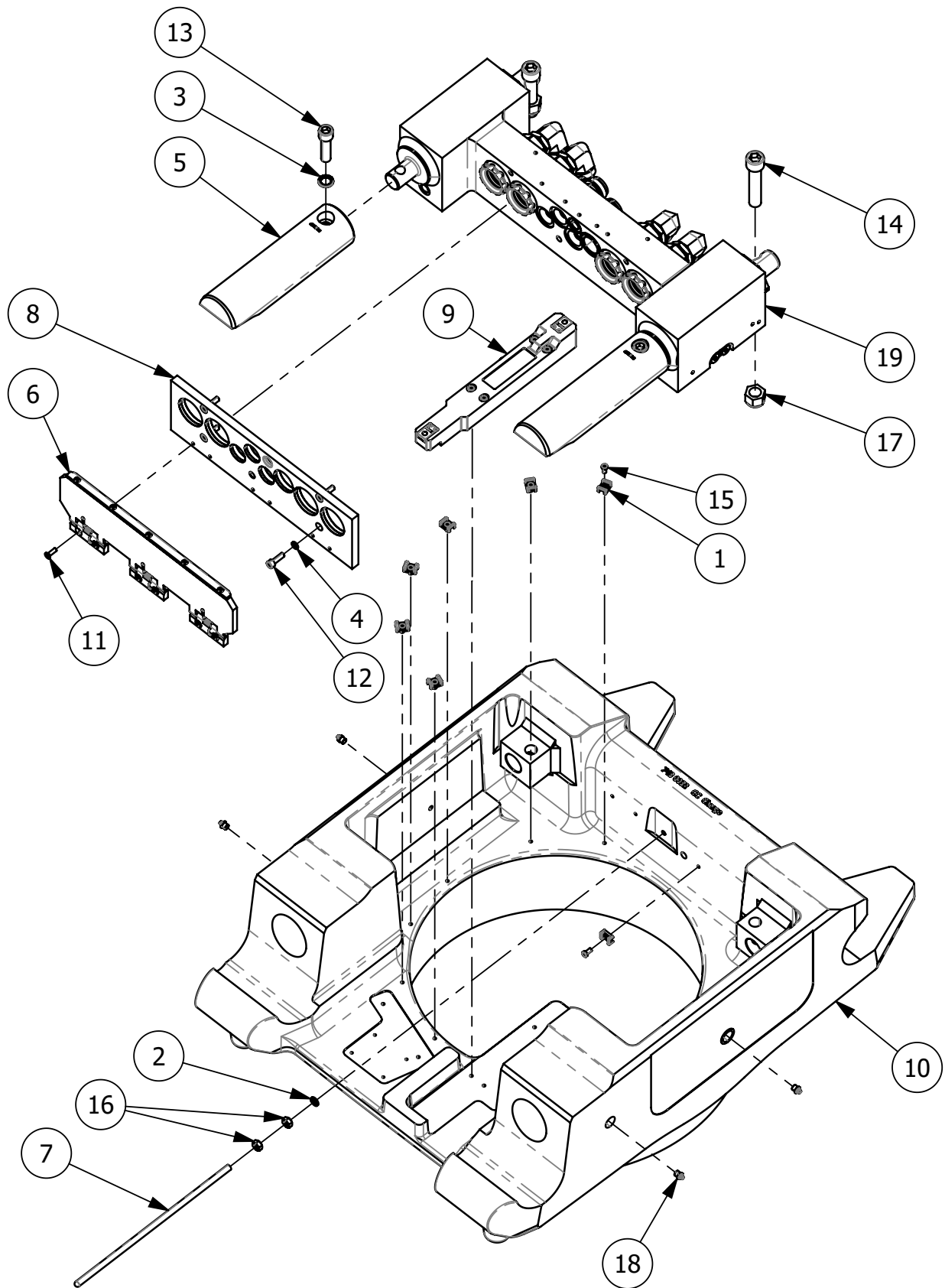

ITEM	PART NO.	NAME	QTY	UOM
1	30-00867	CABLE TIE MT FOR .35" X .13" CABLE TIE	7	EA
2	50-00682	WASHER NORDLOCK M10 - 16.6 X 2.5 1244	1	EA
3	50-00734	WASHER NORDLOCK M16 - 25.4 X 3.3 1536	2	EA
4	50-00773	WASHER NORDLOCK M8 - 13.5 X 2.5 1231	4	EA
5	OQ4114794	LOCKING PLUNGER OQ90	2	EA
6	OQ4114818	DIRT GUARD OQ90	1	EA
7	OQ4114819	OPENING BAR OQ90	1	EA
8	OQ4120223	GUIDE PLATE OQ90	1	EA
9	OQ4131164	REAR SENSOR (CHASSIS) OQLS 2.0 OQ90	1	EA
10	OQ5113143	OQC90 CHASSIS	1	EA
11	OQ7060091	SCREW MF6S M6x20 10.9	6	EA
12	OQ7060094	SH CS M8 - 1.25 X 25 Z_12.9	4	EA
13	OQ7060159	SH CS M16 X 60	2	EA
14	OQ7060161	SH CS M20 - 2.50 X 100 Z_12.9	2	EA
15	OQ7060285	SH CS M6 -1.00 X 12 Z_12.9 LOW PROFILE	7	EA
16	OQ7065006	NUT M10 X 1.50 Z_10.9	2	EA
17	OQ7065007	NUT NYLOCK M20 X 2.50 Z_10.9	2	EA
18	OQ7205005	FTG-ZERK M10 X 1.5	4	EA
19	OQE07457	ASSY H-CYLINDER 2.0 OQC90	1	EA

## 2.0 - COUPLER

### 2.2 - OQE07457 - ASSY H-CYLINDER 2.0 OQC90

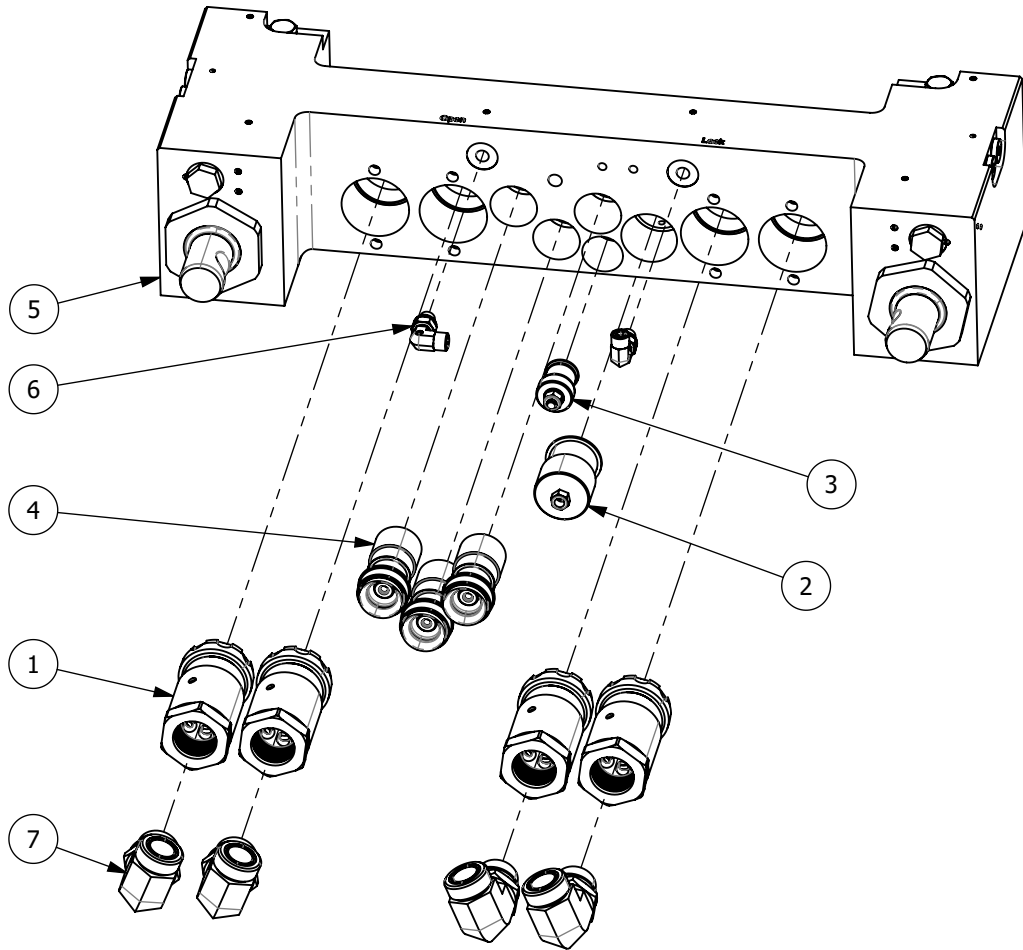
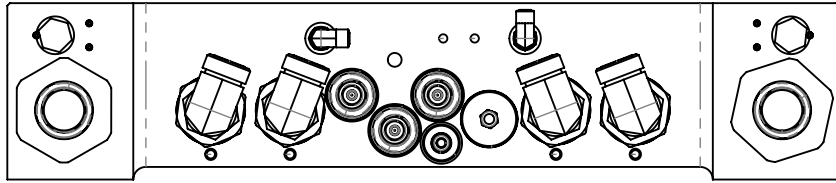

ITEM	PART NO.	NAME	QTY	UOM
1	OQ4118454	HYDRAULIC COUPLING 1" - M33 FEMALE	4	EA
2	OQ4121134	POLY ADAPTER 3/4", H-CYLINDER	1	EA
3	OQ4121140	POLY ADAPTER 1/4"+3/8" H-CYLINDER	1	EA
4	OQ4126375	ELECTRICAL COUPLING 1/2" FEMALE -100 AMP	3	EA
5	OQ5113088	H-CYLINDER OQ90-OQC90	1	EA
6	OQ7200210	FTG-HYD 12MM- 04MO 90	2	EA
7	OQ7200229	FTG-HYD FOX16 M33x2 UF 90° adj	4	EA



## 2.0 - COUPLER

### 2.3 - OQC90 GUARDS

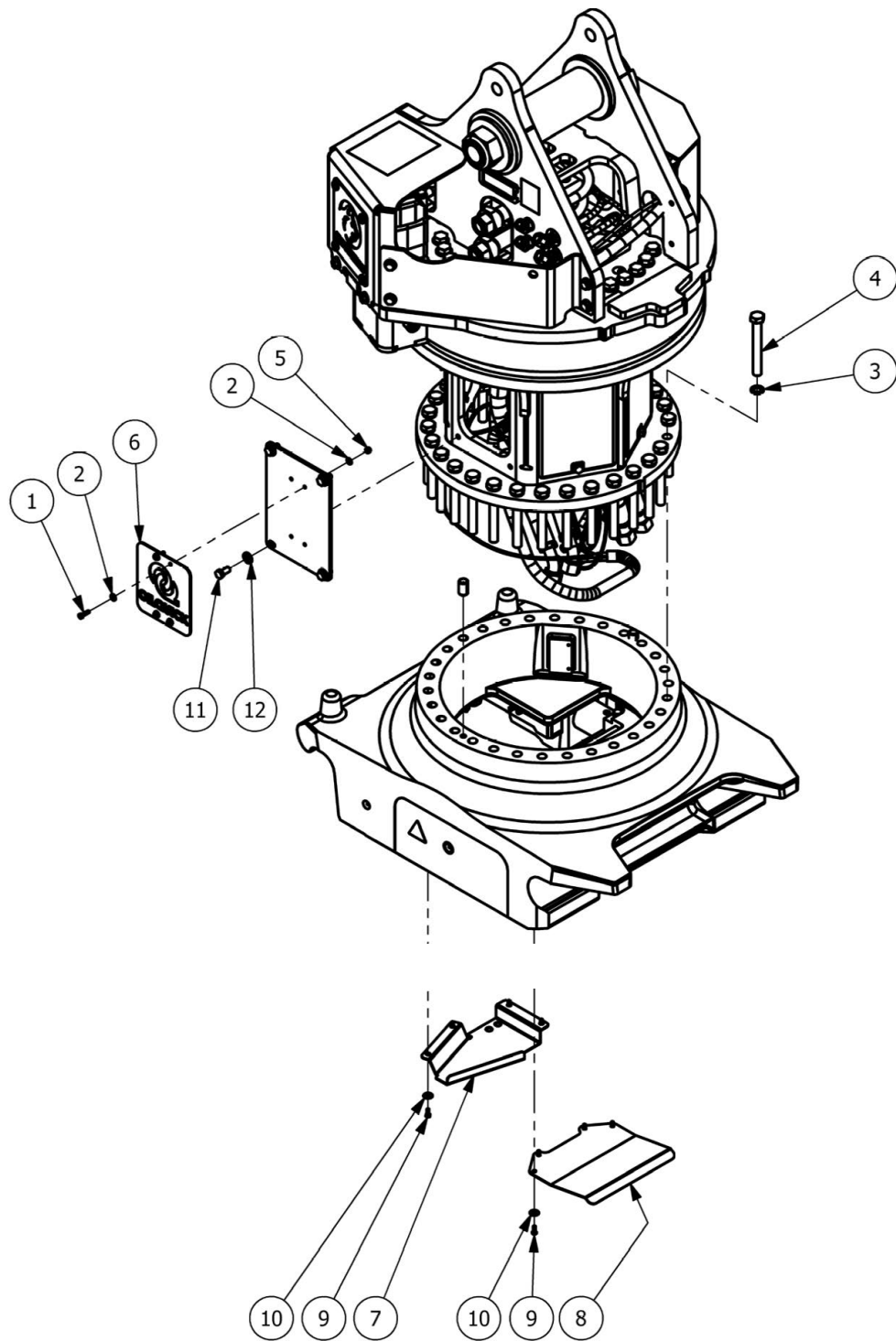

ITEM	PART NO.	NAME	QTY	UOM
1	50-00121	HH CS 0.250 - 20 X 1.000	8	EA
2	50-00122	WASHER 0.250 - 0.63 X 0.07 Z H	16	EA
3	50-00816	WASHER NORDLOCK M20 - 30.7 X 3.4	30	EA
4	50-01139	HH CS M20 - 2.50 X 160 P_10.9	30	EA
5	50-01331	NUT NYLOCK .250 - 20 Z 8	8	EA
6	OQ4134166	EMBLEM - OILQUICK OQC90	2	EA
7	OQ4134673	PROTECTIVE PLATE REAR SENSOR	1	EA
8	OQ4139192	PROTECTIVE PLATE MAG	1	EA
9	OQ7060188	Screw A4-80 M6S M6x16	8	EA
10	OQ7072029	WASHER FNDR M6 - 28.0 Z	8	EA
11	50-00468	HH CS 0.500 - 13 X 1.00 Z_8	8	EA
12	50-00090	WASHER 0.500 X 1.06 X 0.10 Z_H	8	EA

## 2.0 - COUPLER

### 2.4 - OQ4126375 - ELECTRICAL COUPLING 100A 1/2"

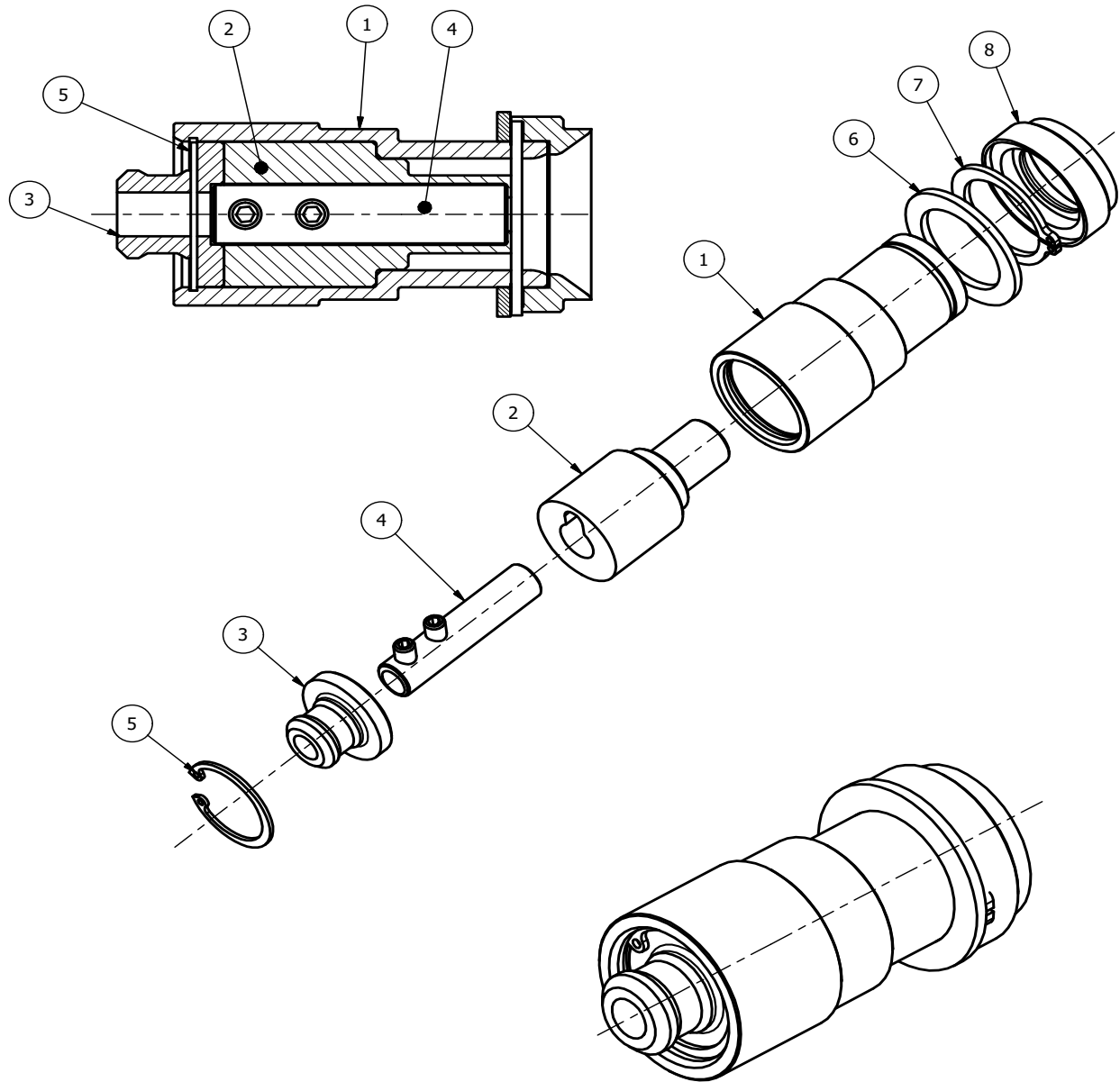

ITEM	PART NO.	NAME	QTY.	UOM
1	OQ4126372	FEMALE COUPLING BODY 1/2"	1	EA
2	OQ4126373	ISOLATOR FEMALE ELEC, COUPLING	1	EA
3	OQ4126374	ELECTRICAL COUPLING RETAINER	1	EA
4	OQ7039036	CONTACT SLEEVE 100A P1/100 BS FEMALE	1	EA
5	OQ7170017	CIRCLIP SGH 30 FEMALE 1"	1	EA
6	OQ7072037	WASHER SUPPORT M30 - 41.7 X 2.4	1	EA
7	OQ7170020	CIRCLIP AS - 30 T=2,0	1	EA
8	OQ4116307	ADAPTER RING 1/2", GUIDE PLATE	1	EA

## 2.0 - COUPLER

### 2.5 - REAR SENSOR

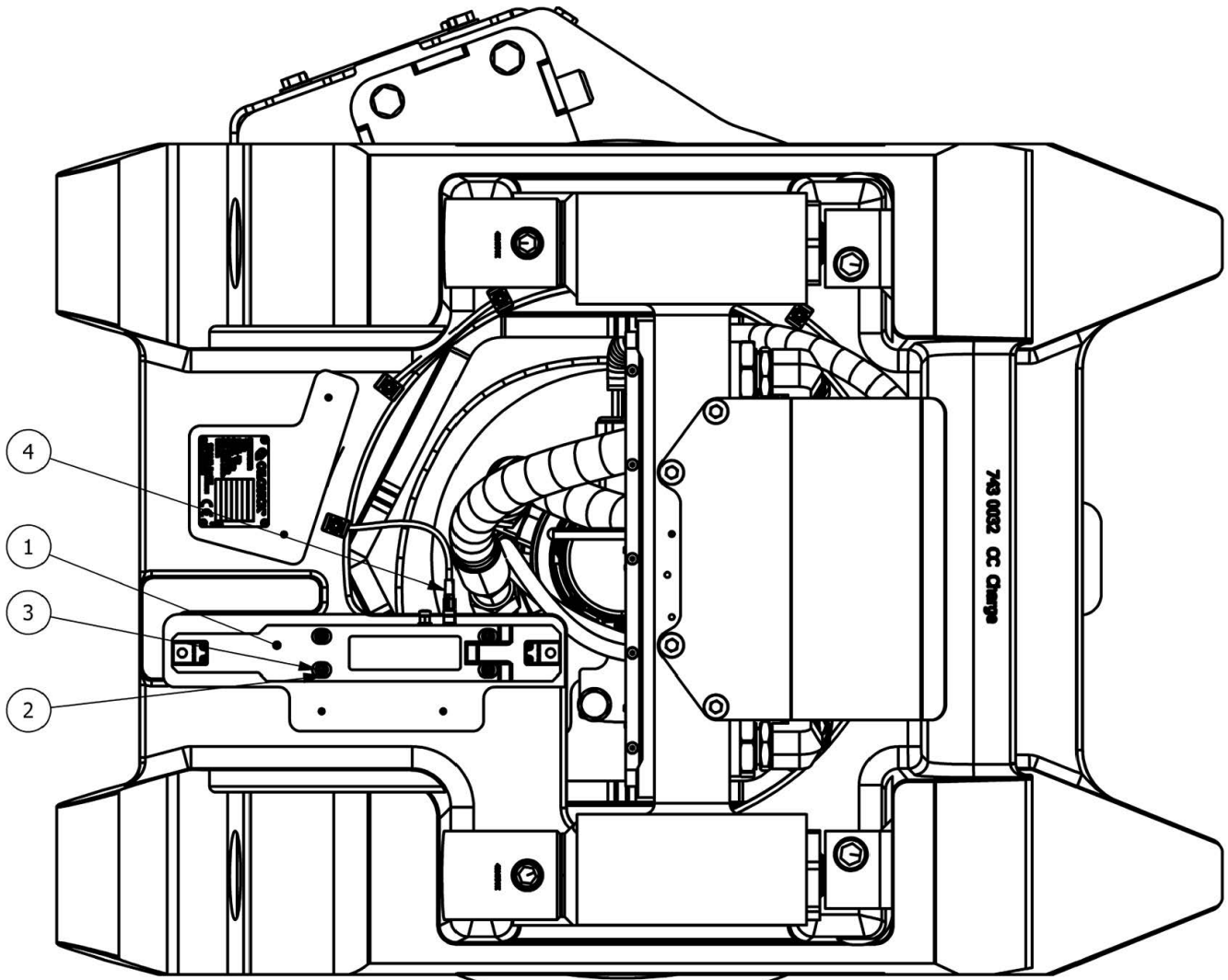

ITEM	PART NO.	NAME	QTY	UOM
1	OQ4131164	REAR SENSOR (CHASSIS) OQLS 2.0 OQ90	1	EA
2	50-00905	WASHER NORDLOCK M6 - 10.8 X 1.8 1519	4	EA
3	OQ7060233	SHCS M6 - 1.00 X 40 Z_12.9	4	EA
4	OQE07421	CABLE-18" M8 6-POS MALE M12 5-POS FEMALE	1	EA

### 3.0 - ADAPTER PLATES

#### 3.1 - OQ5113070 - HYDRAULIC ADAPTER BRACKET

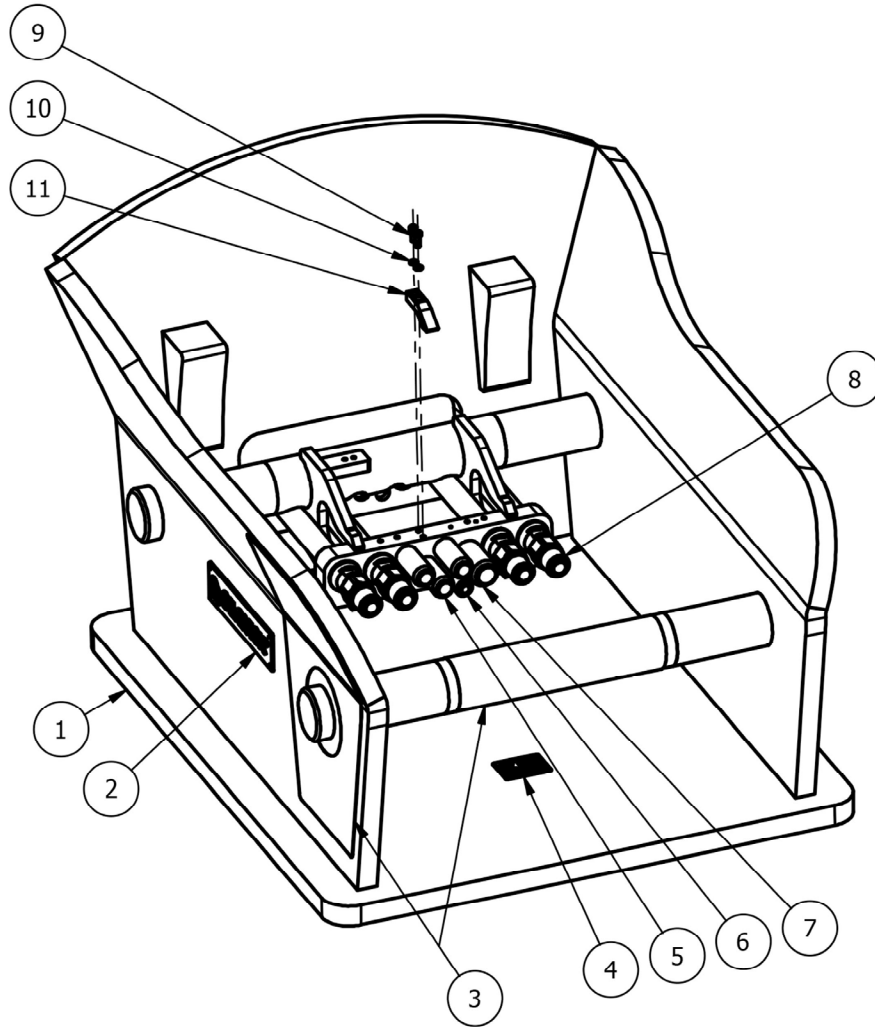

ITEM	PART NO.	NAME	QTY	UOM
1	-	ADAPTER PLATE OQC90	1	EA
2	OQ4116271	EMBLEM - OILQUICK - OQ70-OQ120	2	EA
3	OQ5180129	STICKER KIT OQC90	1	EA
4	OQE04743	SERIAL TAG - OILQUICK AMERICAS	1	EA
5	OQ4112668	POLY ADAPTER 1/2" OQ70-90	3	EA
6	OQ5113014	POLY ADAPTER 1/4" & 3/8" OQ90	1	EA
7	OQ4112670	POLY ADAPTER 3/4" OQ70-90	1	EA
8	OQ5113015	COUPLING KIT 1" LONG OQ90 OQC90	4	EA
9	OQ7060133	SH SCREW MC6LS M8 - 1.25 x 20 10.9	2	EA
10	50-00773	WASHER NORDLOCK M8	2	EA
11	OQ4114829	DEFLECTOR- OQ90 OQC90	1	EA

### 3.0 - ADAPTER PLATES

#### 3.2 - OQ5113069 - MAGNET ADAPTER BRACKET

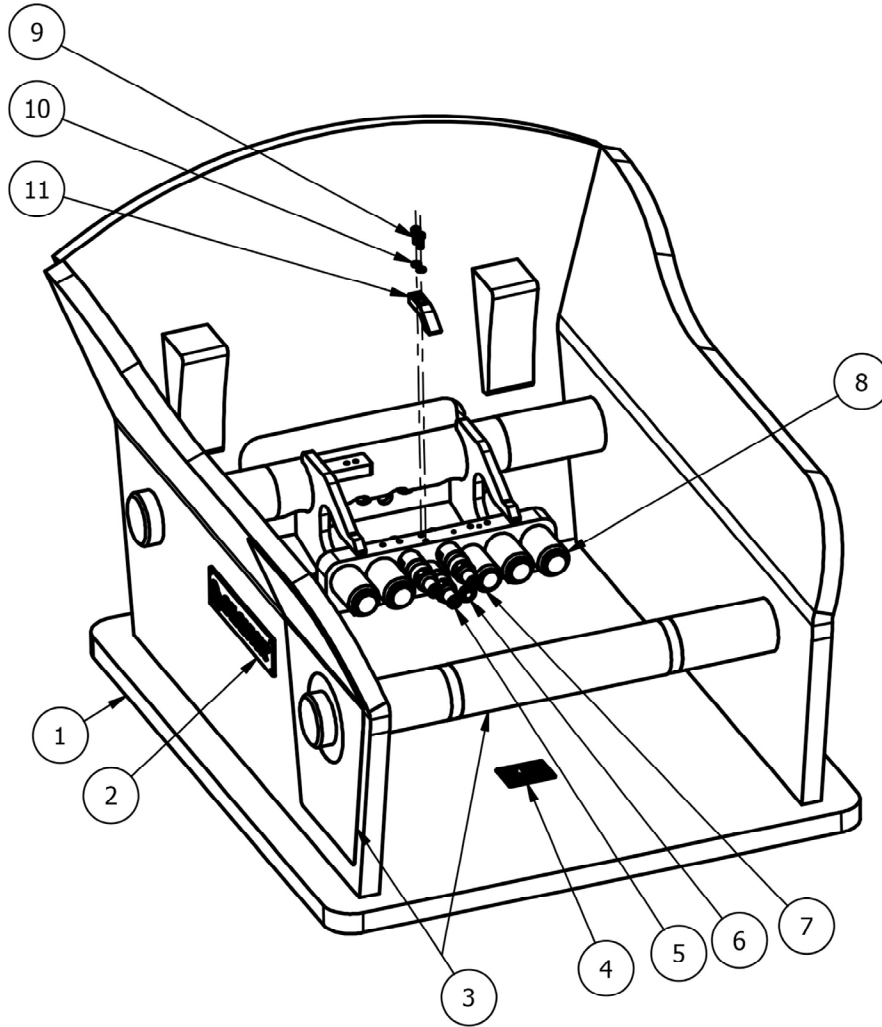

ITEM	PART NO.	NAME	QTY	UOM
1	-	ADAPTER PLATE OQC90	1	EA
2	OQ4116271	EMBLEM - OILQUICK - OQ70-OQ120	2	EA
3	OQ5180129	STICKER KIT OQC90	1	EA
4	OQE04743	SERIAL TAG - OILQUICK AMERICAS	1	EA
5	OQ4126578	ELECTRICAL COUPLING 1/2" MALE -100 AMP	3	EA
6	OQ5113014	POLY ADAPTER 1/4" & 3/8" OQ90	1	EA
7	OQ4112670	POLY ADAPTER 3/4" OQ70-90	1	EA
8	OQ4112672	POLY ADAPTER 1" OQ70-90	4	EA
9	OQ7060133	SH SCREW MC6LS M8 - 1.25 x 20 10.9	2	EA
10	50-00773	WASHER NORDLOCK M8	2	EA
11	OQ4114829	DEFLECTOR- OQ90 OQC90	1	EA





**Dealer:**



OilQuickAmericas  
155 Main Street  
Superior, WI 54880  
Phone: 262.607.8425  
Fax: 715.395.3703

E-mail: [info@oilquickamericas.com](mailto:info@oilquickamericas.com)  
Web: [www.oilquickamericas.com](http://www.oilquickamericas.com)