



USER MANUAL

OQ40 – OQ120

OilQuick Safety System OQSS



Esteemed OilQuick user

We congratulate you on the purchase of your new OilQuick quick coupler and OilQuick Safety System!

OilQuick is a quick coupler system for excavators between 1 and 120 metric tons.

OilQuick Americas products fulfill the applicable ISO safety regulation for quick coupler safety. It is important that all safety requirements are observed during installation, use and repair of OilQuick products. This applies to the safety regulations in this manual, the safety regulations in the base machine manual, and any local safety regulations that apply for the area in which the machine is used.

The OilQuick Safety System is an electronic control system specially developed for use with excavators equipped with the OilQuick quick coupler system. This manual provides information about the basic functionality and use of the OilQuick quick coupler and OQSS. Read this manual carefully before the OQSS system is installed and used.

The job of a machine operator comes with great responsibility. The operator is responsible for the operations of the machine itself, and more importantly, for their own personal safety and that of any other people near the machine. Therefore, the machine operator must take personal responsibility to familiarize themselves with and understand the machines they operate and their functions.

We have developed OQSS to increase machine and jobsite safety when changing attachments. While OQSS is a monitoring and control system that gives information and guidance, it can never relieve you of your responsibilities to be aware and operate responsibly.

The OilQuick coupler with OQSS has been designed and proven to make your work simpler and more productive as a machine operator. Changes may only be made to OilQuick products with the permission of OilQuick Americas. Any non-factory approved modifications to the OilQuick quick coupler, components, or the OQSS control system will void the manufacturer's warranty and may invalidate adherence to ISO specifications for quick coupler safety.

Please complete and send your warranty card to us as soon as possible.

We hope that you enjoy and benefit from using OilQuick equipment.

1. Important information

Text in boxes as below must be read with extra care because it is important information about certain procedures. If the information is not followed, accidents or injury/damage to persons or property may occur.

Text in boxes as below must be read with extra care because it is important information about important matters.



We retain the right to make technical changes and revisions for any errors.

Copyright © OilQuick Americas

2. Preface

This manual applies to models: OQ40 - OQ120.

Certain parts of the manual can refer to equipment and details that are options and not installed in your system. We request that you ignore these sections if that is the case. A safety conscious user that follows all safety instructions and care for the equipment, minimizes the risk of any injuries and accidents.



Read this manual carefully and check that the installation details with applicable options for installation of the quick coupler system are correctly filled in and signed by the installer before the quick coupler system is taken into operation.



The quick coupler and OQSS may only be used by people who have read this manual and follow the instructions given in the manual.



Transport and lifting of persons using the quick coupler or connected attachments is strictly prohibited!



When shunting, loading and moving attachments, they must be connected and disconnected according to the applicable instructions in this manual. Attachments may not under any circumstances be moved when hanging from the front pin only, regardless of whether the quick coupler is open or closed.



WARNING! Installation: The main task of the OQSS is to control and monitor the open and close functions of the quick coupler. It is of the greatest importance that it is installed by trained personnel. Installation and service may only be carried out by authorized service personnel. Failure to follow this principle can lead to failures in function, damage to property and personal injury.



WARNING! Components: Bear in mind that OQSS is an electronic application. The electronics in the OQSS are very robust and can tolerate large stresses during operation in the most demanding situations such as chiseling and demolition. Damage occurs almost exclusively due to mechanical or external forces and care must therefore be taken when changing attachments and in other situations where electronic components are exposed.

3. Intended Use

OilQuick quick couplers have been developed for excavators, to quickly and safely connect/disconnect mechanical and hydraulic attachments/tools.

The quick coupler must be adapted to the appropriate machine size, attachment dimensions on the excavator, intended use, and the local conditions for use.

Any attachment connected to the quick coupler must be approved for use with the excavator and fitted with the appropriate attachment frame/adaptor from OilQuick.

Short term use of the quick coupler under water is permitted provided the coupler is not equipped with a thru electrical coupling to the attachment connection (ex V90). The coupler is rated to IP67, meaning it can be submerged at a depth of 1 meter for a period of thirty (30) minutes.

An excavator with connected quick coupler must only be used at a workplace that is protected or restricted. For more information about requirements for the excavator, see "Technical data".

The attachment coupler must not be used for work (aside from lifting per section 4) without a connected attachment.

The user bears all responsibility for damage that occurs through inappropriate use and the manufacturer accepts no liability.



Unauthorized modifications or additions to the quick coupler entail a risk of accidents resulting in severe personal injury or fatality.

- **Only use the quick coupler on an excavator approved for the coupler (see type plate and the "Technical data" section) and in a workplace that is protected or cordoned off.**
- **Do not use the quick coupler to hammer, tear, smash or stamp using the attachment or for other purposes it is not intended for.**
- **Do not use the quick coupler to lift people.**
- **Only use the quick coupler if it is in fault-free condition.**

4. Hoisting Hook and Ring

The quick coupler can be equipped with a hoisting hook/ring as an option. This hoisting hook/ring may only be used to lift weights using appropriate and approved lifting items (chains or lifting straps). The lifting aid is hooked onto the hoisting hook or ring.

Information about the maximum lifting capacity is shown on the hoisting hook/ring.



Use the hoisting hook/ring on the quick coupler for purposes that it was not intended, entails a risk of accidents resulting in severe personal injury or fatality.

- **Use the hoisting hook/ring together with a suitable and approved lifting aid.**
- **Do not exceed the maximum load of the hoisting hook/ring.**
- **Only use the hoisting hook/ring if it is in fault-free condition.**

5. Table of Contents

1. Important information	3
2. Preface	4
3. Intended use	5
4. Hoisting hook and ring	5
5. Table of contents	6
6. Description of components in OilQuick quick coupler system	9
6.1. Quick coupler	9
6.2. H-cylinder for locking and opening	9
6.3. OQSS	9
6.4. Attachment frames/adapters	10
6.5. Electrical connection, V-90 (optional)	10
6.6. Electrical connection, straight (optional)	10
7. Description of OilQuick Safety System (OQSS)	11
8. OQSS basic system and options	12
8.1. Basic system	12
8.2. Options that are not machine dependent	12
8.3. Options that are machine dependent	12
9. Operating principle OQ Safety System	13
10. Mechanical and hydraulic operating principle	14
11. Functional diagram and installation requirements	15
12. Locking hydraulics on excavators	16
13. Technical data	17
13.1. Dimensions and forces	17
13.2. Electrical components	18
13.3. Attachment frames/adapters	19
13.4. Attachment specific bracket	20
13.5. Hydraulic components in the quick coupler	21
13.6. Dimensions and positioning of quick couplings	22
14. Installation of quick coupler	24
15. Description of control panel for OQSS	27
15.1. OQSS coupler status indication	28
15.2. Opening/closing the quick coupler	29
16. Correctly connected attachment	30
17. Closed without attachment, for hook hoist, transport etc.	31
18. Open quick coupler	31

5. Table of Contents - *continued*

19. Connection of attachments	32
19.1. Connection of vertically connected attachments	32
19.2. Connection of horizontally connected attachments	34
19.3. Connection of vertically connected attachments with pendulum adapter	36
19.4. Connection of horizontally connected attachments with pendulum adapter	38
20. Lock test of attachments	40
20.1. Attachments without hydraulic function	40
20.2. Attachments with hydraulic function	41
21. Disconnection of attachments	41
21.1. Disconnection of vertically connected attachments	41
21.2. Disconnection of horizontally connected attachments	43
21.3. Disconnection of vertically connected attachments with pendulum adapter	44
21.4. Disconnection of horizontally connected attachments with pendulum adapter	46
22. Description of system faults and notification	48
22.1. Navigation of the fault screen	49
23. Emergency operation	49
24. System menus	50
24.1. System status screens	51
24.2. System setup screens	52
24.3. Troubleshooting screens	55
24.4. Fault log screens	56
25. Use of hoisting hook/ring	57
26. Start and stop of machine at service and maintenance	57
27. Inspection and maintenance	58
27.1. Daily inspection	58
27.2. End of day inspection	59
27.3. Monthly inspection	59
28. Maintenance - OQSS system components	60
29. Maintenance of quick coupling	61
29.1. Replacement of nose seal in female coupling	61
29.2. Replacement of lock ring secured quick couplings	62
30. Plates and decals	64

5. Table of Contents - *continued*

31. Troubleshooting - Quick coupler	65
32. Troubleshooting - OQSS	66
33. Hydraulic schematic (OQE06747)	68
34. Electrical schematic (OQE06358)	70
34.1. Wiring diagram (OQ06748)	72
35. OilQuick Americas "Approved OEM Locking Hydraulics"	74
35.1. Considerations when using OilQuick Americas OQSS System	75
36. Lock sensor adjustment check procedure	76
36.1. Field lock sensor adjustment procedure	76
37. OilQuick Product Warranty Registration	77

6. Description of components in OilQuick quick coupler system

6.1 - Quick coupler

1. Coupler body
2. Side plate
3. Guide pin
4. Stick pin bore
5. Link pin bore
6. Hoisting hook (optional)
7. Hoisting ring (optional)
8. Front pin holder
9. Support surface for rear pin of attachment frame/ adapter
10. Locking bolt
11. Lubrication nipple

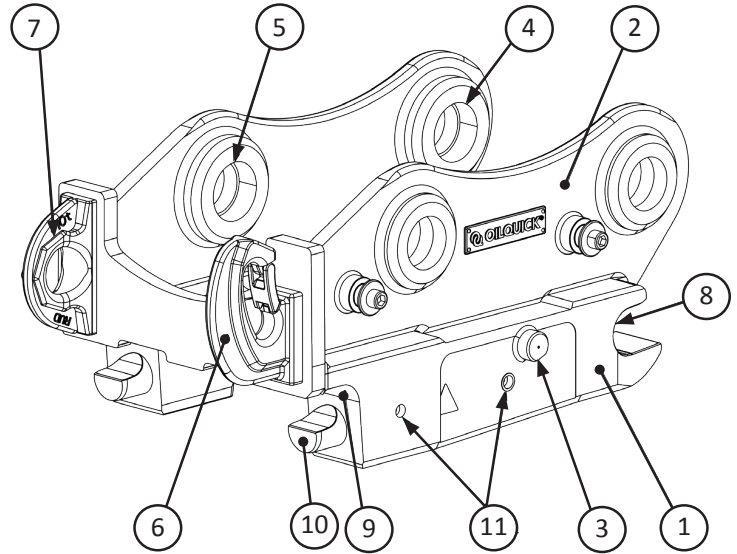

6.2 - H-cylinder for locking and opening

1. H-cylinder
2. Hydraulic hoses for locking and opening
3. Locking bolts
4. Dirt guard
5. Quick coupling (female)

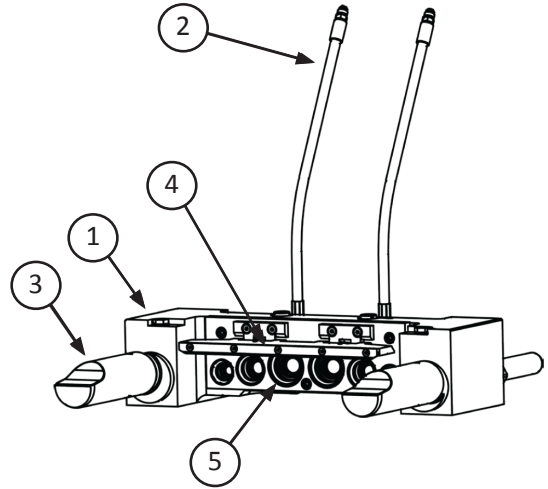

6.3 - OQSS

1. Display module
2. Chassis module
3. Lock sensor
4. Wire harness kit

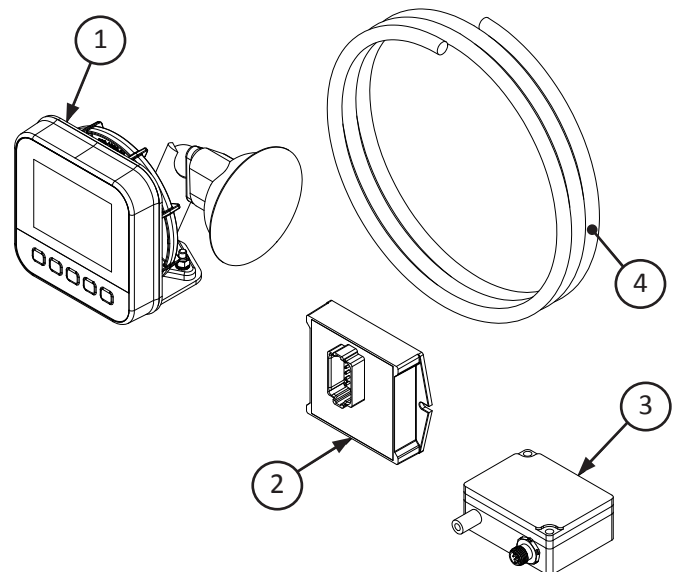

6. Description of components in OilQuick quick coupler system - *continued*

6.4 - Attachment frames/adapters

1. Front pin
2. Rear pin
3. Side plate
4. Collision protection
5. Cut-outs for guide pins
6. Coupling ramp
7. Quick couplings (male)

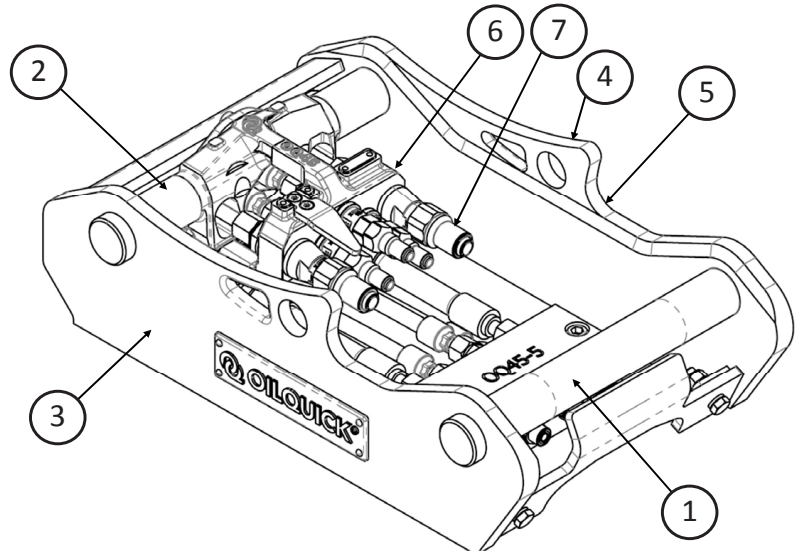

6.5 - Electrical connection, V-90 (optional)

NOTE! Not available on OQ 40/24 and OQ 40-5.

1. Female connection (quick coupler)
2. Male connection (attachment)

Electrical connector is 10 pin.

Connection device version and its contact can vary.

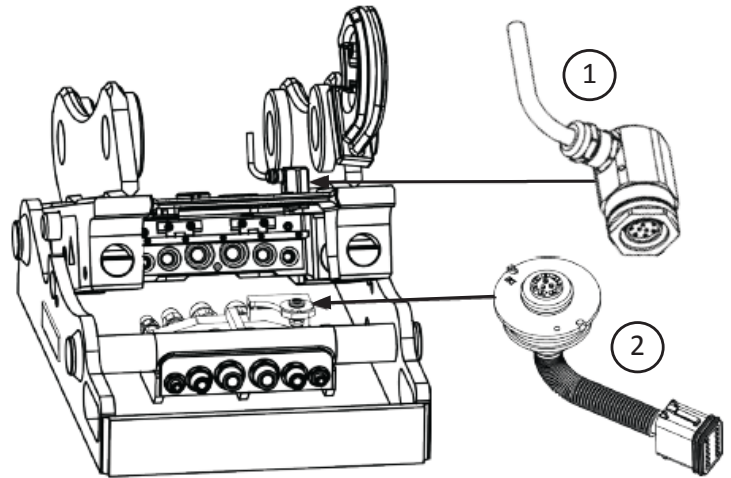

Installation of V-90, vertical electric connection does not affect the possible number of hydraulic quick couplings in the quick coupler and hydraulic attachment frame/adaptor.

6.6 - Electrical connection, straight (optional)

1. Female connection (quick coupler)
2. Male connection (attachment)

1/4" electrical connector is 6 pin. 1/2" & 3/4" electrical connector is 10 pin.

1/2" & 3/4" Single conductor - High AMP

Connection device version and its capacity can vary.

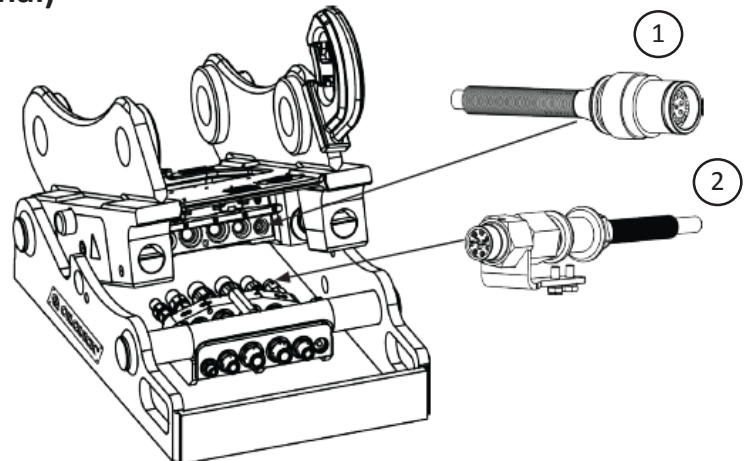

7. Description of OilQuick Safety system (OQSS)

OQSS contains

1. Display module installed in the cab.
2. Chassis module, normally installed in the area of the machine for electrical systems or hydraulic pumps.
3. Wire harness kit
4. Lock sensor
5. Locking valve with load sense function
6. Pressure relief valves (option)
7. Pressure sensor

On installation this must be supplemented with hoses and nipples for connection to pump and tank and hoses for connection to the quick coupler.



Approximate component mounting locations.

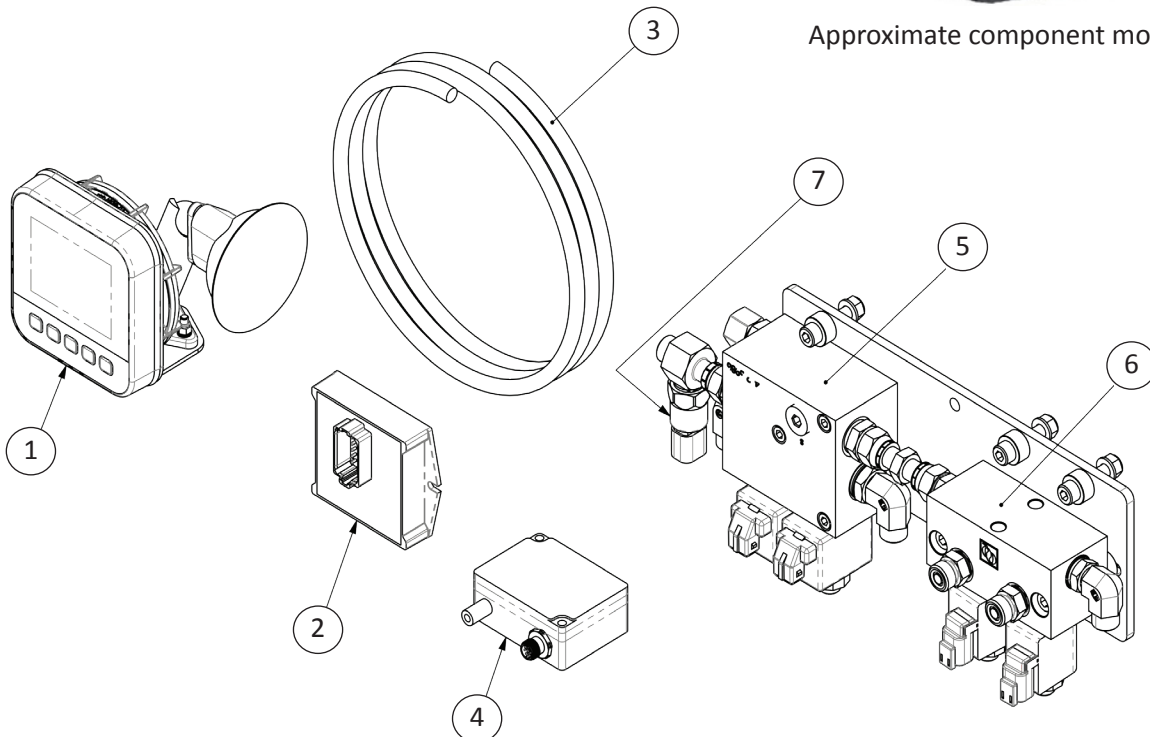

8. OQ Basic system and options

OQSS is a control and monitoring system for quick couplers on an excavator. The system consists of a basic system and a number of options depending how the base machine is equipped.

8.1 - Basic system

1. Display module installed in the cab.
2. Chassis Module, normally installed in the area of the machine for electrical systems or hydraulic pumps.
3. Lock sensor
4. Cable kit for connections between the relevant system components.

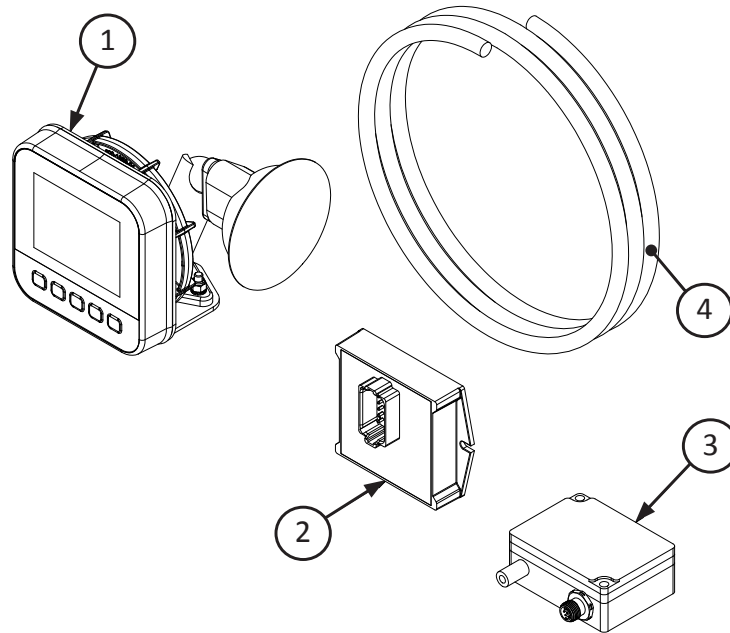

8.2 - Options that are not machine dependent

- Connection to the machine control arm, strongly recommended option.
- Pressure relief valve with accessory for relieving operating hydraulics.

8.3 - Options that are machine dependent

- Cable kit for connection to the electrical system on machines that have approved locking hydraulics and control of pressure booster.
- Lock valve for operating the quick coupler on machines that do not have factory installed approved locking hydraulics.
- Valve for controlling the machine's pressure booster for machines with LS-system.
- Combined lock and pressure booster valve for machines with LS-system but without approved locking hydraulics.
- Connection to the machine generator enable circuit. (Required for machines equipped with a generator).

9. Operating principle OQ Safety System

The OQSS display module in the cab is the operator's interface with the quick coupler system. The display screen indicates the quick coupler system operating status and gives visual and audible alarms when dangerous situations occur. The buttons below the screen allow the operator to open and close the quick coupler in a controlled and monitored way.

The OQSS system monitors the status of the quick coupler and safety sensors and displays the status on the display module. The chassis module controls the locking valve, pressure booster and pressure relief valves, and reads the safety sensors. The display module indicates alarms both visually and audibly. Any abnormal operating conditions will be indicated by a fault warning on the display screen, along with an audible beep from the alarm. The alarm also provides audible feedback in normal conditions. When the coupler is open or opening, there is a constant slow pulsed tone. When a lock cycle is initiated, this changes to a fast pulsed tone. When the coupler is locked or closed without an attachment connected, the audible alarm stops.

OQSS is equipped with optional electronic interlocks preventing coupler operation if certain criteria are not met. The first optional interlock is intended to read the excavator control arm signal and prevent coupler operation if the control arm is not actuated. The second optional interlock is intended to read the control signal from a machine mounted generator and prevent coupler operation anytime the generator is enabled. These optional interlocks can be enabled within the system setup menu and require additional electrical connections to the excavator.

To open the quick coupler both Open buttons on the control panel must be pressed and held for 3 seconds. After 3 seconds the lock valve is energized, the pressure booster and pressure relief valves are energized (option), and the coupler begins to open. When the open cycle is initiated, the alarm sounds a slow pulsed tone. When the locking bolts leave their lock position the coupler icon on the display screen turns red, the locking bolts are no longer visible, and "OPEN" text is displayed above the coupler icon. The coupler is now open, and the alarm will continue to sound a slow pulsed tone. When the quick coupler is moved to a position out of the attachment bracket, without any attachment pins in position the operator can close the coupler for hook hoisting, transport or service. The operator presses and holds the Lock button for 1 second. The lock valve is de-energized, and the pressure boost (option) and relief (option) valves are energized. The audible indication from the buzzer turns to a fast pulsed tone. The quick coupler is closed when the coupler icon on the screen turns gray and "CLOSED NO TOOL" is indicated above the coupler icon. The audible alarm turns off, and the coupler is now able to be used for lifting operations or machine transport.

To connect an attachment the operator must first open the coupler, then properly position the quick coupler into the attachment bracket. When the quick coupler is correctly positioned in the attachment bracket the operator may press and hold the Lock button for one second to initiate a lock cycle. The lock valve is de-energized, and the pressure boost and pressure relief (option) valves are energized. The audible indication from the buzzer turns to a fast pulsed tone. The coupler icon on the screen will turn gray with locking bolts shown until sufficient lock pressure has been achieved. The indicator light on the coupler itself lights green in this condition. The quick coupler is properly locked into the attachment bracket when the coupler icon on the screen turns green with locking bolt and pins showing, "LOCKED" text is indicated above the coupler icon, and the indicator light on the coupler lights green. The audible alarm turns off when the coupler is determined to be in the properly locked position.



Lock test must always be performed after connecting an attachment!
See "Lock test of attachments".

9. Operating principle OQ Safety System - *continued*

A self-test of all components and the system status is performed on each startup. If an error is found during this diagnosis an alarm is triggered and displayed on the screen to inform the operator that a dangerous situation has occurred. Further, the system is continuously monitoring for faults and will visually and audibly indicate if a fault becomes present. Certain dangerous faults disable the coupler open function. In this case, Emergency Operation mode can be used to operate the coupler until the fault can be corrected. Measures to be taken during an error, and emergency coupler operation are described in a separate section of this manual.

All system faults are logged by the OQSS system. The 28 most recent faults are arranged in chronological order and are identified based on system startup count. Fault logs can easily be viewed on the display module. System startups and coupler cycles are also recorded and viewable within the system status pages of the display module.

OilQuick systems installed on machines that do not have the ability to integrate a pressure boost function require a machine function to be safely operated to build pressure, such as running the bucket cylinder to the limit position, raising the dozer blade or similar.

10. Mechanical and hydraulic operating principle

The quick coupler consists of a coupler body in which the H-cylinder with accessories is mounted. The quick coupler is mounted on the excavator stick and link. The H-cylinder (3) and locking bolts move forwards and backwards when oil is supplied to the H-cylinder. When the H-cylinder is in the front position (3:1) the locking bolts are retracted (1:1) in the coupler body and an attachment can be connected/disconnected. When the H-cylinder is in the rear position (3:2) the locking bolts are extended (1:2) and, if in place, an attachment frame/adaptor is connected to the quick coupler.

The quick couplings (4) are located in the H-cylinder's intermediate section between the locking bolts. The quick couplings are protected by a dirt guard (2) when they are not in use. This dirt guard is opened automatically when the H-cylinder is in the front position (2:1) and closes automatically in the rear position (does not apply if a hydraulic attachment is connected (2:2)).

Oil is supplied to the H-cylinder via the excavator's hydraulic system and locking valve for the hydraulic quick coupler. When connecting hydraulic attachments, the hydraulic quick couplings and any electrical couplings are connected at the same time the tool is locked mechanically.

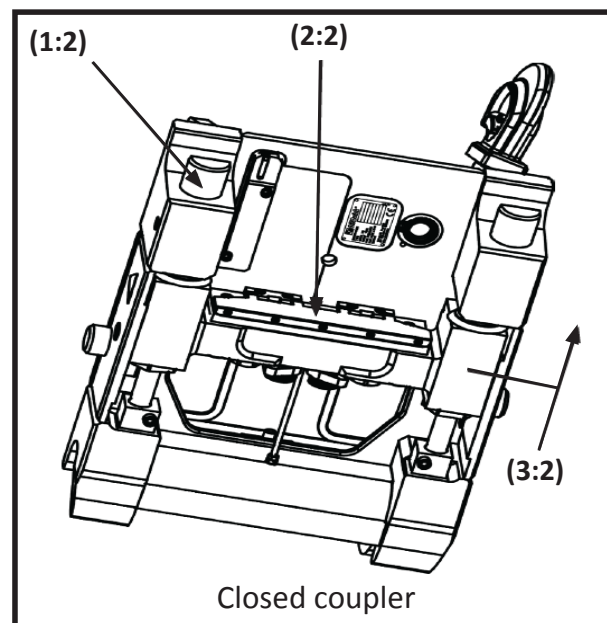
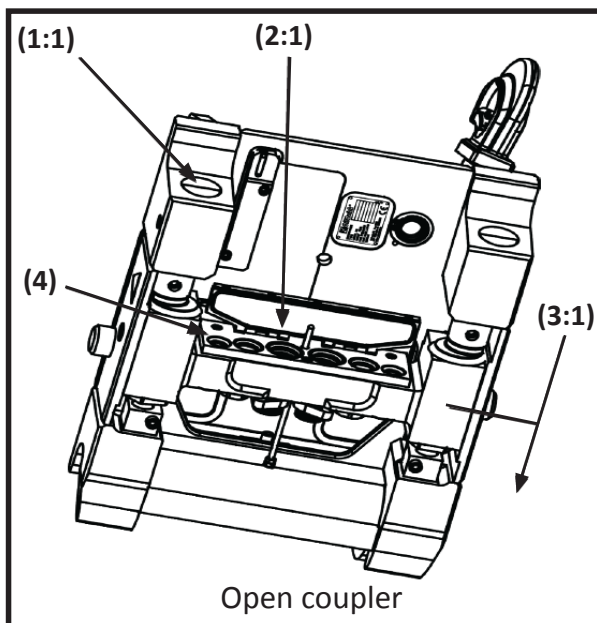

11. Functional diagram and installation requirements



Lock test must always be performed after connecting an attachment!
See "Lock test of attachments".



OilQuick quick coupler system H-cylinder must:

- Have direct connection to pump.
- Have direct tank return.
- Lock with the machine's maximum pressure in the operating hydraulics.



NOTE! Before OilQuick quick coupler is installed on the excavator the machine supplier must be contacted for instructions regarding suitable connection points for hydraulics and electronics.

The main component of the quick coupler is the H-cylinder. Together with the locking bolts, the H-cylinder holds the connected attachment and the hydraulic quick couplings in the correct position. The H-cylinder hydraulic diagram is shown below.

1. H-cylinder integrated lock cylinders
2. Pilot operated check valves
3. Pressure limiter
4. Lock valve for the machine's quick coupler system
5. Pressure boost valve
6. Pressure sensor
7. Auxiliary relief valve

In modern machines, both pressure and flow from the machine's pressure booster (5) vary depending on the machine load. Unlike many others, OilQuick quick coupler systems work with the machine's maximum operating pressure. It is necessary to have a play-free and precise lock between the quick coupler and the attachment frame/adaptor. The H-cylinder must also hold the quick couplings together in the correct way. When the attachment is connected pressure in the extend side of the cylinders (1) builds up to the machine's max pressure.

The two pilot operated check valves (2) maintain pressure in the cylinders (1) when machine pressure varies. Each time the pump pressure increases the cylinders are refilled (1). If the pressure in the cylinder (1) exceeds 45 MPa the pressure relief valves (3) start to open to tank (8) and reduce pressure. To open the quick coupler and disconnect the attachment, the lock valve (4) is activated. The rod side of the H-cylinder is then pressurized, the pilot operated check valves (2) open, and the H-cylinder opens. If the oil supply to the H-cylinder ceases (for example a hose ruptures) it is prevented from opening, because the pilot operated check valves (2) ensure that the oil cannot leave the H-cylinder unless the rod side is pressurized.

The lock valve (4) pressure line P must be directly connected to the machine pump for operating hydraulics. This is to ensure that the H-cylinder is always pressurized.

The lock valve (4) return line T must be directly connected to the machine's hydraulic tank without restriction (8) to ensure a pressure free return line.

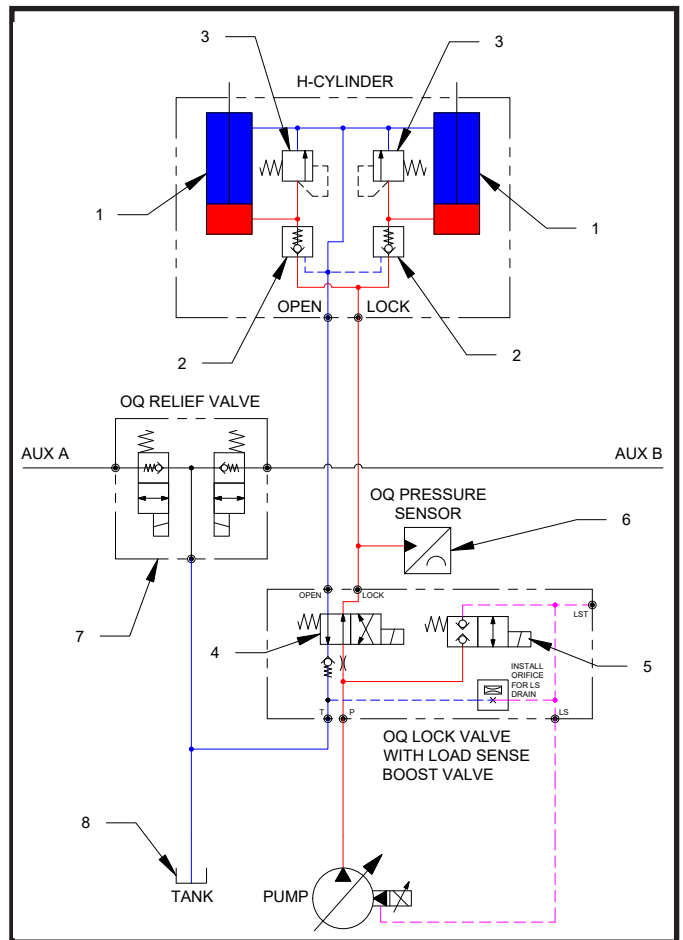

12. Locking hydraulics on excavators

The OilQuick quick coupler system requires that the locking hydraulics are controlled with the same pressure as the machine's main operating hydraulics. The OilQuick Safety System, which controls and monitors the attachment status requires an approved locking valve for opening and closing the coupler and a function for boosting the machine pressure to relief when the attachment lock is operated. The conditions to obtain these functions are different from machine to machine and therefore require different solutions at installation. The following gives three typical installation methods depending on the machine's equipment level and technology.

1. OilQuick lock / open valve installed to operate the quick coupler via OQSS system. Locking pressure is achieved by actuating a machine function to bring the pumps on stroke at relief pressure. This is the most common installation where an approved locking valve is not factory supplied with the base machine.
2. Control of the factory installed approved locking valve via OQSS system. OQSS lock / open valve cable is connected to machine locking valve. Machine locking valve may require reconfiguration in certain cases. Locking pressure is achieved by actuating a machine function to bring the pumps on stroke at maximum operating pressure.
3. OilQuick combination lock / open and pressure boost valves installed to operate the quick coupler and boost machine pressure via the OQSS system. Locking pressure is achieved by sending a pressure signal through the machine load sense circuit. This configuration only works with machines that utilize load sense control pump systems.

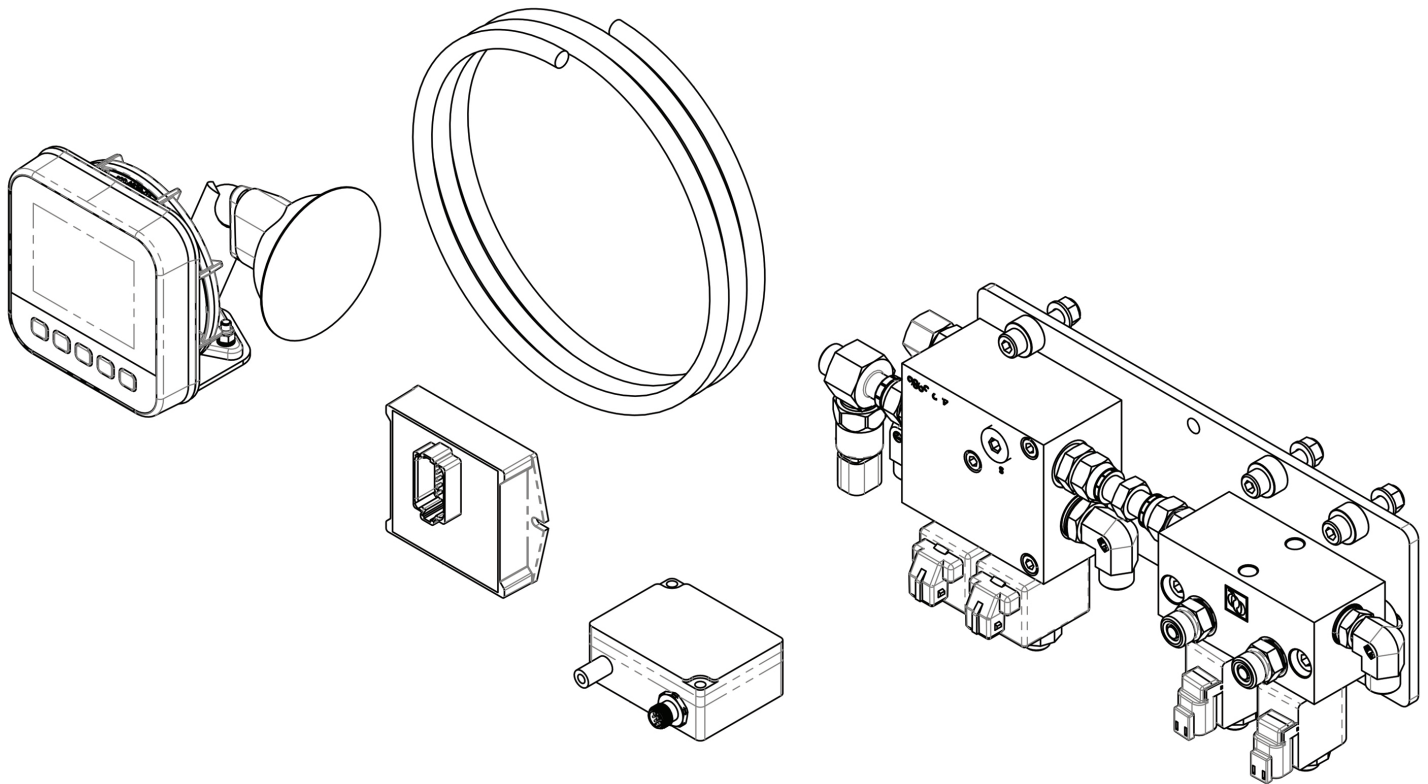

For basic hydraulic installation requirements for OilQuick quick coupler system, see chapter "Functional diagram and installation requirements"

13. Technical data

Quick coupler design follows Nordic S-standard for non-hydraulic attachments.

13.1 - Dimensions and forces

Dimensions

Model	Machine Weight Class (TONS)	C-C Measurement Pin Class (mm) (A)	Measurement Pin Diameter (mm) (B)	Width (mm) (D)	Weight (kg)
OQ 40/24	1–5	300	40	240	See ID plate
OQ 40-5	1–5	300	40	270	See ID plate
OQ 45-4/OQ 45-5	5–12	430	45	290	See ID plate
OQ 60-4/OQ 60-5	12–18	480	60	340	See ID plate
OQ 65	14–22	530	65	440	See ID plate
OQ Rail	14–22	530	65	440	See ID plate
OQ 70	15–28	600	70	450	See ID plate
OQ 70/55	18–30	600	70	550	See ID plate
OQ 80	25–40	670	80	590	See ID plate
OQ 90	40–70	750	90	750	See ID plate
OQ 120	70–120	925	120	870	See ID plate

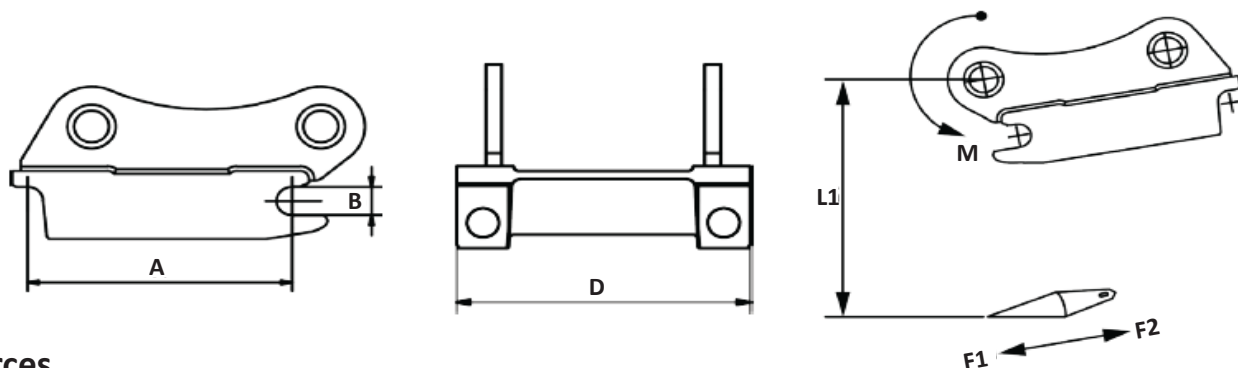

Forces

Model	Max Breaking Torque (kNm) (M)	Bucket Radius (mm) (L1)	Force in Bucket Cut (kN) (F)
OQ 40/24	40	550	72
OQ 40-5	40	550	72
OQ 45-4/OQ 45-5	70	800	87
OQ 60-4/OQ 60-5	150	1050	145
OQ 65	240	1050	230
OQ Rail	240	1050	230
OQ 70	320	1250	255
OQ 70/55	450	1500	300
OQ 80	700	1700	410
OQ 90	900	1850	485
OQ 120	1250	2600	480

13.2 - Electrical components

Electrical couplings

Electrical Coupling Model	1/4"	1/2"	3/4"	V90
Number of contact pins in electrical connector	6	10	10	10
Max current per contact pin in electrical coupling (continuous)	3A	5A	5A	5A
Max current per contact pin in electrical coupling (intermittent, 5 seconds)	5A	8A	8A	8A
Max current total across all contact pins (continuous)	10A	15A	15A	15A
Max current total across all contact pins (intermittent, 5 seconds)	12A	20A	20A	20A
Max current per contact pin in electric connection when attachment is disconnected	300mA	500mA	500mA	500mA

OQSS

Inputs	
Supply voltage, V_{in}	9 – 30V
Fuse	10A
Outputs	
Lock activate	V_{in} - Max 2,8A
Pressure boost	V_{in} - Max 2,8A
Pressure relief	V_{in} - Max 2,8A (2x)

13.3 - Attachment frames/brackets

The table below shows technical data for the most common types of attachment frames and brackets. For more information, contact nearest OilQuick representative.

Attachment frame for mechanical attachments (rotatable)

Model	Internal width (mm)	Pin distance (mm)	Pin diameter (mm)	Approx. weight (kg)
OQ 40/24	240	300	40	14
OQ 40-5	270	300	40	15
OQ 45-4/OQ 45-5	290	430	45	25
OQ 60-4/OQ 60-5	340	480	60	50
OQ 65	440	530	65	65
OQ Rail	440	530	65	65
OQ 70	450	600	70	85
OQ 70/55	550	600	70	90
OQ 80	590	670	80	150
OQ 90	750	749	90	250
OQ 120	870	925	120	600

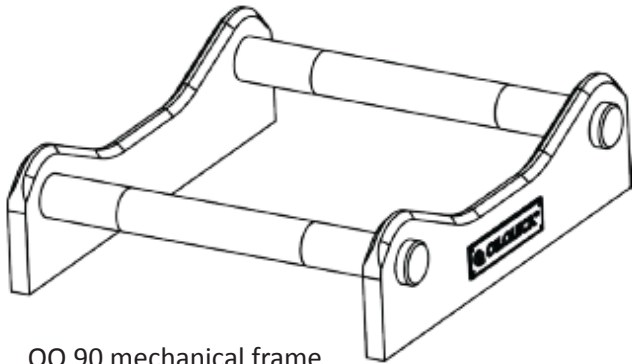

OQ 90 mechanical frame

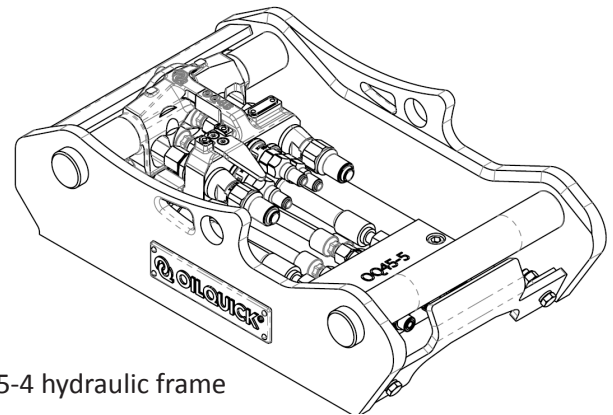

OQ 45-4 hydraulic frame

Attachment frame for hydraulic attachments

Model	Internal width (mm)	Pin distance (mm)	Pin diameter (mm)	Approx. weight (kg)
OQ 40/24	240	300	40	17
OQ 40-5	270	300	40	19
OQ 45-4/OQ 45-5	290	430	45	35
OQ 60-4/OQ 60-5	340	480	60	55
OQ 65	440	530	65	75
OQ Rail	440	530	65	75
OQ 70	450	600	70	95
OQ 70/55	550	600	70	120
OQ 80	590	670	80	170
OQ 90	750	749	90	270
OQ 120	870	925	120	620

13.4 - Attachment specific brackets

Model	Internal width (mm)	Pin distance (mm)	Pin diameter (mm)	Approx. weight (kg)
OQ 40/24	240	300	40	68
OQ 40-5	270	300	40	90
OQ 45-4/OQ 45-5	290	430	45	100
OQ 60-4/OQ 60-5	340	430	60	200
OQ 65	440	530	65	240
OQ Rail	440	530	65	240
OQ 70	450	600	70	315
OQ 70/55	550	600	70	340
OQ 80	590	670	80	420
OQ 90	750	749	90	670
OQ 120	870	925	120	1350

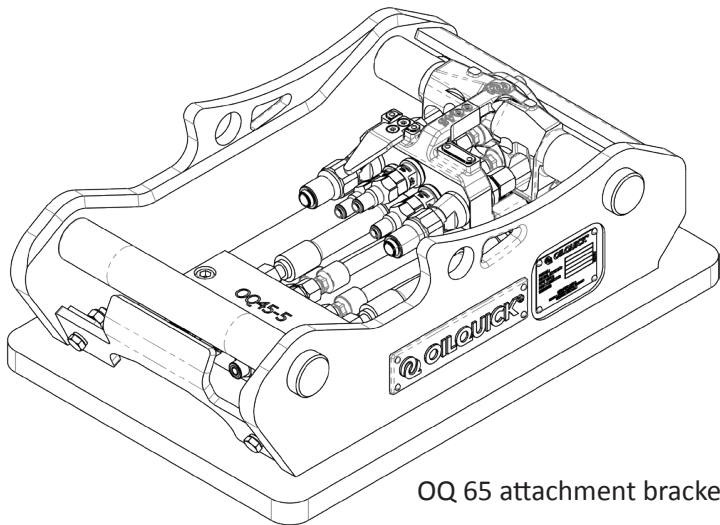

OQ 65 attachment bracket

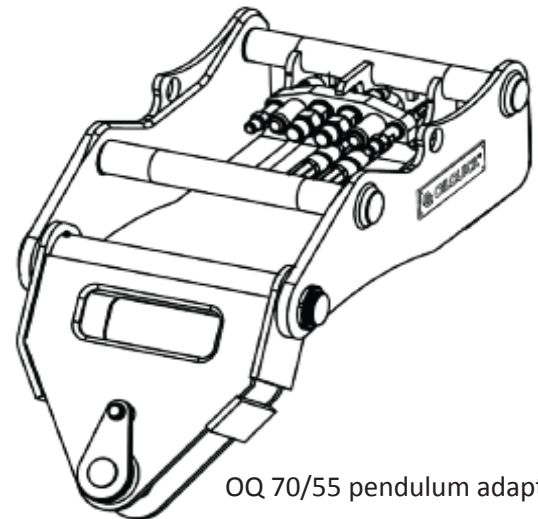

OQ 70/55 pendulum adapter

Pendulum adapter

Model	Internal width (mm)	Pin distance (mm)	Pin diameter (mm)	Approx. weight (kg)
OQ 40/24	–	–	–	–
OQ 40-5	–	–	–	–
OQ 45-4/OQ 45-5	290	430	45	See ID plate
OQ 60-4/OQ 60-5	340	480	60	See ID plate
OQ 65	440	530	65	See ID plate
OQ Rail	440	530	65	See ID plate
OQ 70	450	600	70	See ID plate
OQ 70/55	550	600	70	See ID plate
OQ 80	590	670	80	See ID plate
OQ 90	750	749	90	See ID plate
OQ 120	–	–	–	–

13.5 - Hydraulic components in the quick coupler

Hydraulic oil	
Viscosity classes	ISO VG 32, 46 & 68
Mineral oil	ISO 6743-4, HM and HV: SS155434, AV and BV: DIN 51524 HVLP
Environmentally friendly oil	DIN 51524 part 3: SS 155434, AV och BV
Oil temperature	-25°C to 80°C
Ambient temperature	-25°C to 55°C

The quick coupler has two parallel hydraulic cylinders, the following technical data applies:

Model	Max operating pressure (Mpa)	Load holding/hose rupture valves	Pressure relief valves	Piston/piston rod, diameter (mm)	Stroke length (mm)	Combined lock force at 10 Mpa (kN)
OQ 40/24	35	Yes	Yes	24/14	60	6,3
OQ 40-5	35/42*	Yes	Yes	32/16	60	16,1
OQ 45-4/OQ 45-5	35/42*	Yes	Yes	32/16	59	16,1
OQ 60-4/OQ 60-5	35/42*	Yes	Yes	35/16	60	19,2
OQ 65	35/42*	Yes	Yes	40/20	65	25,1
OQ Rail	35/42*	Yes	Yes	40/20	65	25,1
OQ 70	35/42*	Yes	Yes	50/30	70	39,3
OQ 70/55	35/42*	Yes	Yes	55/30	75	47,5
OQ 80	35/42*	Yes	Yes	55/30	75	47,5
OQ 90	35/42*	Yes	Yes	60/35	100	56
OQ 120	35/42*	Yes	Yes	80/45	129	100

* Generation 2.0 H-cylinders are rated for a max operating pressure of 42 MPa.

Following technical data applies to quick couplings:					
Coupling dimensions	3/8"	1/2"	3/4"	1"	1 1/2"
Oil flow at 0.3 Mpa pressure drop (l/min). Stated valve only applies to quick couplings.	35	70	140	250	800 *
Max continuous operating pressure (Mpa)	35	35	35	35	35

Higher flow rates are possible with increased pressure drop.

* Theoretical value

13.6 - Dimensions and positioning of quick couplings



The actual appearance of the couplings varies. This is determined by the machine's attachment hydraulics and which attachments are to be used in the system solution. Questions regarding this should be directed to your nearest OilQuick dealer.

The location of the couplings is viewed from the cab.

OQ 40/24	
Coupling 1 and 4	1/2"
Coupling 2 and 3	3/8"
Coupling 1 and 2	Replace with electric coupling

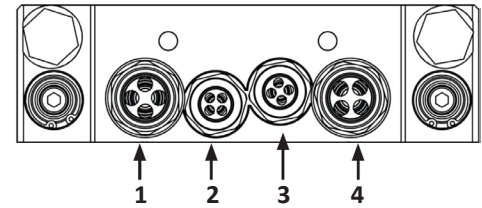

OQ 40-5	
Coupling 1 and 5	1/2"
Coupling 2 - 4	3/8"
Coupling 1 and 3	Replace with electric coupling

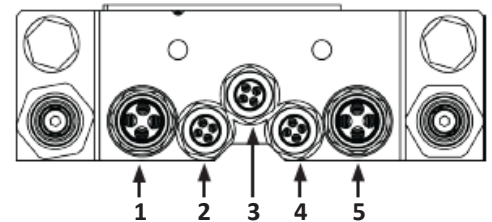

OQ 45-4	
Coupling 1 - 4	1/2"
Coupling 1	Replace with electric coupling

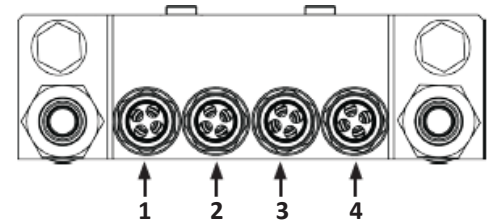

OQ 45-5	
Coupling 1 and 5	1/2"
Coupling 2 - 4	3/8"
Coupling 1	Replace with electric coupling

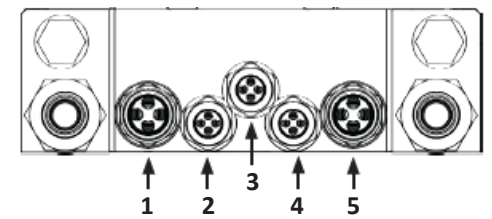

OQ 60-5	
Coupling 1 and 5	3/4"
Coupling 3	1/2"
Coupling 2 and 4	3/8"
Coupling 3	Replace with electric coupling

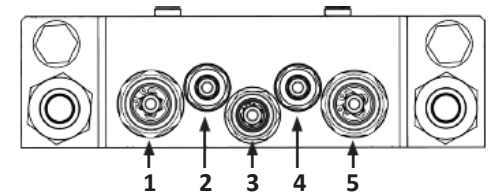

OQ 65	
Coupling 1 and 5	1/2"
Coupling 2-4	3/4"
Coupling 1 and 3	Replace with electric coupling

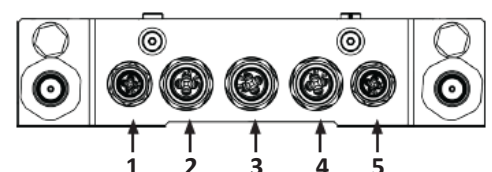

13.6 - Dimensions and positioning of quick couplings - *continued*

OQ Rail	
Coupling 1, 7 and 8	3/4"
Coupling 2-6	1/2"

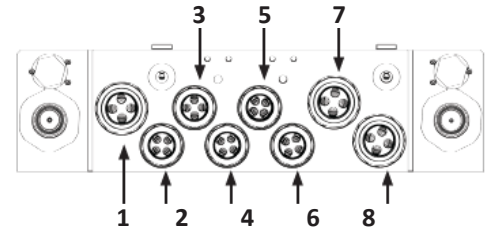

OQ 70	
Coupling 1 and 5	1/2"
Coupling 3	3/4"
Coupling 2 and 4	1"
Coupling 1 and 3	Replace with electric coupling

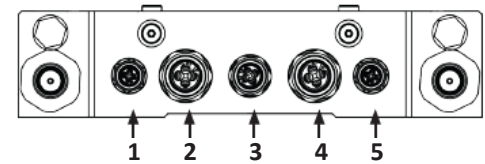

OQ 70/55 and OQ 80	
Coupling 1 and 6	1/2"
Coupling 2 and 5	3/4"
Coupling 3 and 4	3/8"
Coupling 1 and 2	Replace with electric coupling

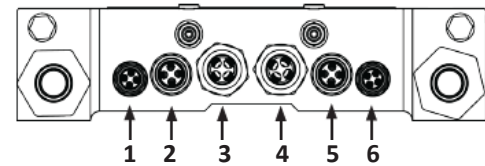

OQ 90	
Coupling 1, 2, 8 and 9	1"
Coupling 7	3/4"
Coupling 3 - 5	1/2"
Coupling 6	3/8"
Coupling 4, 6 and 7	Replace with electric coupling

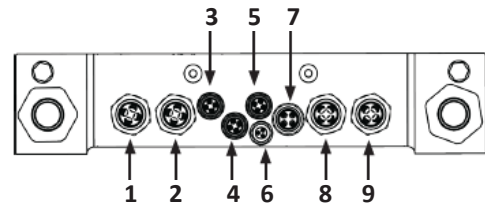

OQ 120	
Coupling 1 and 8	1-1/2"
Coupling 3, 4 and 7	1"
Coupling 2, 5 and 6	1/2"

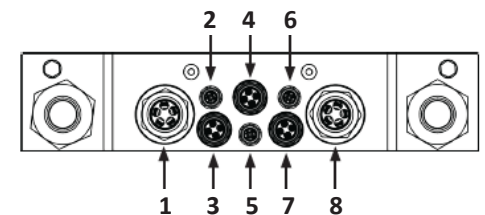

14. Installation of quick coupler



WARNING!

There is a risk of physical harm when installing the quick coupler.



For further information regarding the installation of the quick coupler, see separate installation manual.

The following requirements must be met when installing the OilQuick quick coupler system:

- The pins for the stick and link must fit and lock in a secure way.
- The lock hydraulics pressure side (LOCK) must have a direct connection to the pump and the machine's full operating pressure.
- The lock hydraulics return side (OPEN) must have a free unrestricted return to the tank.
- Hydraulic components that are used for the installation must be of the same or higher pressure classification than the machine's operating pressure.
- The machine manufacturer's instructions for installing the quick coupler must otherwise be followed.

The quick coupler is supplied to the location for installation in transport packaging. This packaging should not be removed until the quick coupler is to be installed. The packaging also simplifies moving the quick coupler.

Great care must be taken when installing the quick coupler on the machine. There are large and heavy parts and failure to proceed in the correct way could result in severe injury.

When working with the hydraulic system the following points must be observed:

- Depressurize hydraulic accumulators and the hydraulic system on the machine.
- Follow machine manufacturer's instructions to place machine in a zero energy state.
- Preserve the environment, clean up every oil spillage.
- Protective gloves must be used, long term exposure to hydraulic oil can cause allergic reaction.
- Protective eyewear should be used to prevent oil splashes to the eyes.
- Cleanliness must be observed when working on hydraulic systems. There is a risk of malfunction if contaminants enter the system.

14. Installation of quick coupler - *continued*

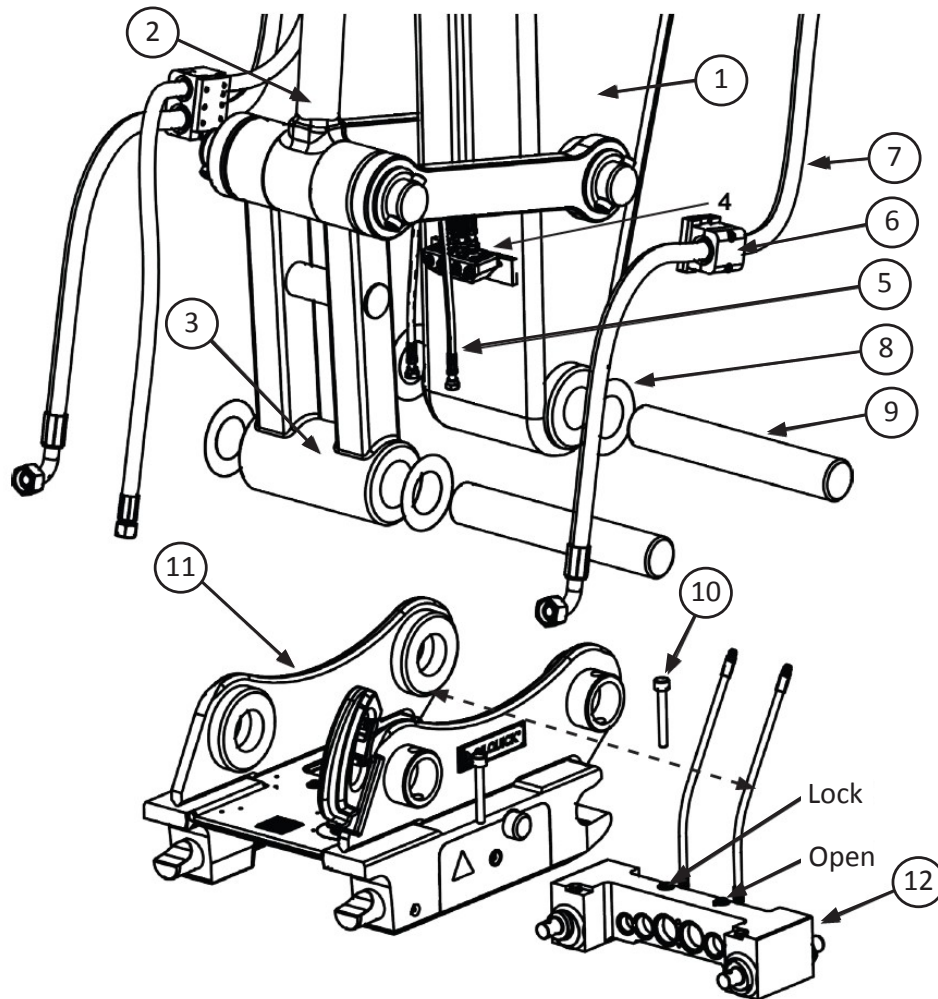

1. Dipper stick
2. Bucket cylinder
3. Link
4. Guide block
5. Connection for lock/open hoses
6. Hose clamps
7. Hydraulic hose
8. Shim washer
9. Pin
10. Pin retention fastener
11. Quick coupler
12. H-cylinder

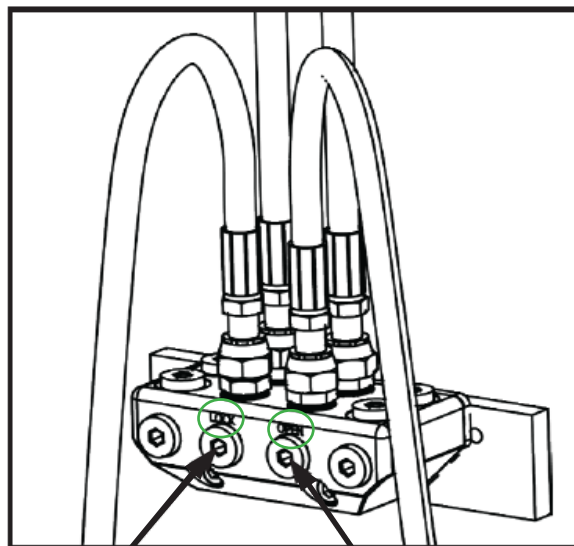

Lock port - measurement instrument can be connected (G1/4" or M12x1.5).

Open port - measurement instrument can be connected (G1/4" or M12x1.5).

14. Installation of quick coupler - *continued*

Hose routing should be in accordance with the images below. Hose routing is individual to each machine type and installation. Hoses must be routed in such a way that a sufficient bend radius is maintained and that abrasion and twisting are avoided. Hose clamp positions and hose lengths are tested on site. It is important to check what the hose routing looks like at the respective limits of the excavator link movement, see images below. Different models of hose clamps are available to suit different types of installations. The nearest OilQuick representative can assist with selection and procurement of the correct model. A guide block is ideal for use with the lock hydraulics, to connect the hoses from the excavator to those that run down to the H-cylinder. This guide block provides a practical installation of the lock hydraulics hoses which are routed inside the machine's excavator linkage. The guide block also has measurement sockets for measuring the H-cylinder locking pressure. Ensure that the hydraulic hoses and hose clamps between the coupling and the dipper stick are free from pinch points and cannot be damaged during articulation.

Examples of correctly executed hose routing:

1. The hose routing with the bucket cylinder in the shortest position.
2. The hose routing with the bucket cylinder in the intermediate position.
3. The hose routing with the bucket cylinder in the longest position.
4. Hose routing seen diagonally from above around adjacent components on the dipper stick (red marked).

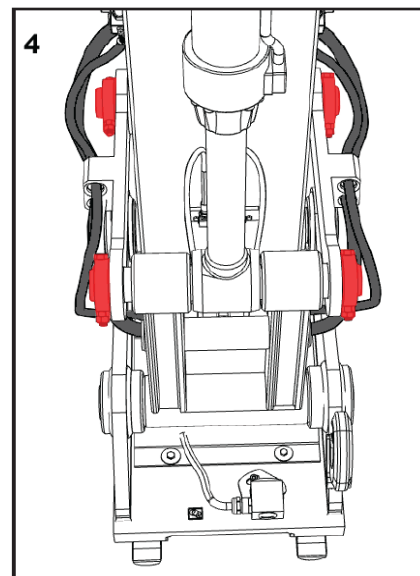
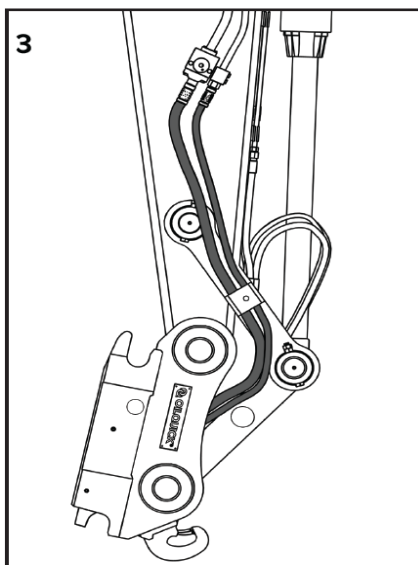
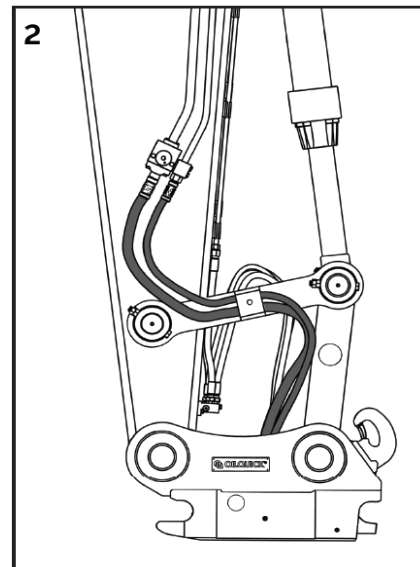
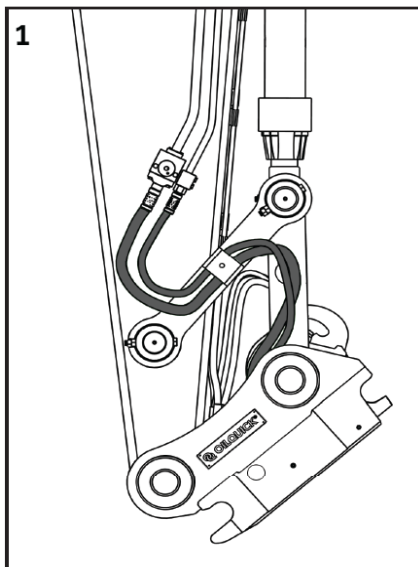

15. Description of Control Panel for OQSS



If the start procedure given below does not occur troubleshooting for OQSS must be carried out and any faults corrected!



Lock test must always be performed after connecting an attachment!
See "Lock test of attachments".

At system start:

- Alarm sounds for 1 second during startup check. Any active faults will be indicated on the display.
- Coupler status will be indicated if locked into an attachment by a gray coupler showing locking bolt, along with a pulsed tone from the alarm. When pressure is increased the coupler image will turn green and "LOCKED" status will be shown.
- If coupler is not locked into an attachment, coupler status will display gray with no text indication of OPEN / LOCKED status.

Description control of panel symbols and functions:

"FORCE" text visible when functions have been overridden in troubleshooting mode.

Coupler status text.

Coupler status message indication.

Coupler status icon.

Operation buttons.

Lock / open button hold time indication. "HOLD" text shows and gray status bar fills until buttons have been held for the required amount of time to start a cycle.

Button function icons above each button. Icons change for different functionality based on screen page.

OPEN Icons. Press and hold both buttons below for three seconds to initiate open cycle

LOCK icon. Press and hold button below for one second to initiate LOCK cycle.

MENU icon. Press and hold button below to enter system menus.

Fault indicator. Flashes when a fault is active. Press button below to enter fault detail page.

15. Description of Control Panel for OQSS - *continued*

15.1 - OQSS Coupler Status Indication

Startup, Coupler not Locked



- RED coupler icon without locking bolt or pins.
- Alarm sounds pulsed tone.

Coupler Open



- Red coupler icon without locking bolt or pin.
- Alarm sounds pulsed tone.

Locked, Insufficient Pressure



- Gray coupler icon showing locking bolt without pins.
- Alarm sounds pulsed tone.
- Operate machine function to increase pressure.

Coupler Locked

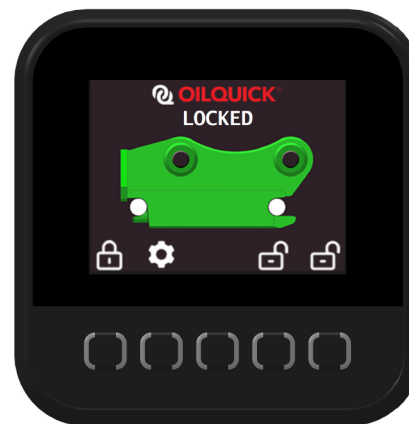

- Green coupler icon showing locking bolt and pins.
- Alarm stops sounding.

Coupler Closed Without Tool



- Grey coupler icon without pins.
- Alarm stops sounding.
- Indicates coupler is closed without attachment to tool.
- Used for hook / ring hoist and machine transport / maintenance.

15. Description of Control Panel for OQSS - *continued*

15.2 - Open/Closing the Quick Coupler

Opening the quick coupler:

- Open the quick coupler by pressing and holding both buttons below the OPEN icons for three seconds.
- Gray status bar above coupler icon fills left to right and begins flashing when the buttons have been held for the required time period. "HOLD" text is shown above OPEN icons for additional indication of required hold time. "HOLD" text turns off and buzzer sounds a pulsed tone when coupler open cycle begins.
- When coupler moves into the open condition, coupler status icon turns red and pins / locking bolt are no longer indicated in the icon.
- The coupler is now open and the attachment can be connected / disconnected.
- Buzzer continues to sound a pulsed tone as long as the coupler is open.



Opening From Coupler Closed Without Tool



Opening From Coupler Locked



Closing the quick coupler:

- Close the quick coupler by pressing and holding the button below the LOCK icon for one second.
- Gray status bar above coupler icon fills left to right and begins flashing when the buttons have been held for the required time period. "HOLD" text is shown above OPEN icons for additional indication of required hold time. "HOLD" text turns off and buzzer sounds a pulsed tone when coupler open cycle begins.
- When coupler moves into the locked condition, coupler status icon turns gray, locking bolt is shown and alarm continues to sound a pulsed tone until sufficient lock pressure has been measured. Operate appropriate machine function to increase pressure.
- Coupler icon turns green with pins / locking bolt visible. Alarm turns off, and "LOCKED" is indicated above the coupler image.
- Coupler is now locked. **A physical lock test must be performed per chapter "Lock test of attachments" prior to any work.**



16. Correctly Connected Attachment

The quick coupler has locked the attachment in both pins and sufficient lock pressure has been achieved. This is indicated by the coupler icon turning green with pins and locking bolt visible, "LOCKED" text is displayed above the coupler icon, and the alarm stops sounding. Further, the indicator light on the coupler will light bright green when the locking bolts are in the correct position.

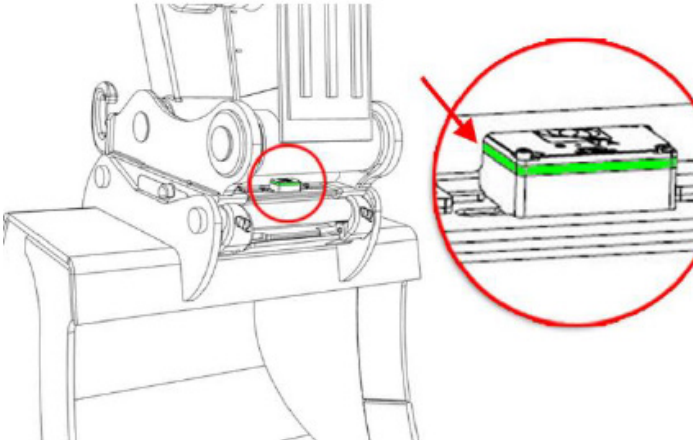

The coupler is ready to lock when engaged in the bracket, as indicated by the rear pin showing on the display on the red coupler image.

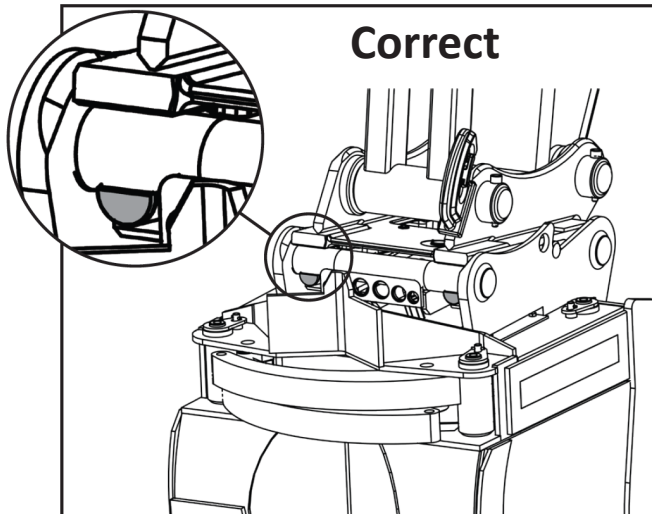

When sufficient lock pressure has been achieved the coupler icon turns green with "LOCKED" indication above coupler image and the coupler is fully locked into the attachment.



Lock test must always be performed after connecting an attachment!
See "Lock test of attachments".

17. Closed without Attachment, for Hoist Hook, Transport, Etc.

In this mode the quick coupler is closed without an attachment connected. This mode is used when working with hoisting hook / ring, performing maintenance, and transport. This is indicated by the coupler icon turning gray without pins visible, "CLOSED NO TOOL" text is displayed above the coupler icon, and the alarm stops sounding.

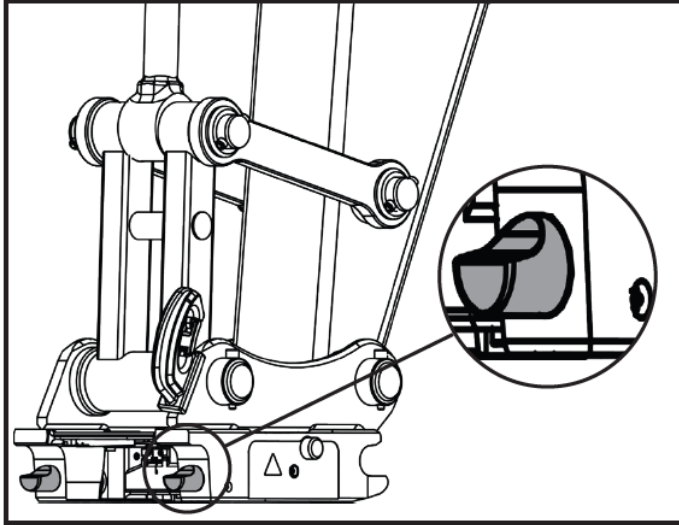

18. Open Quick Coupler

The quick coupler is open and the locking bolts are withdrawn into the coupler body. This is indicated by the coupler icon turning red without pins or locking bolts visible, "OPEN" text is displayed above the coupler icon, and a pulsed tone sounds from the alarm.

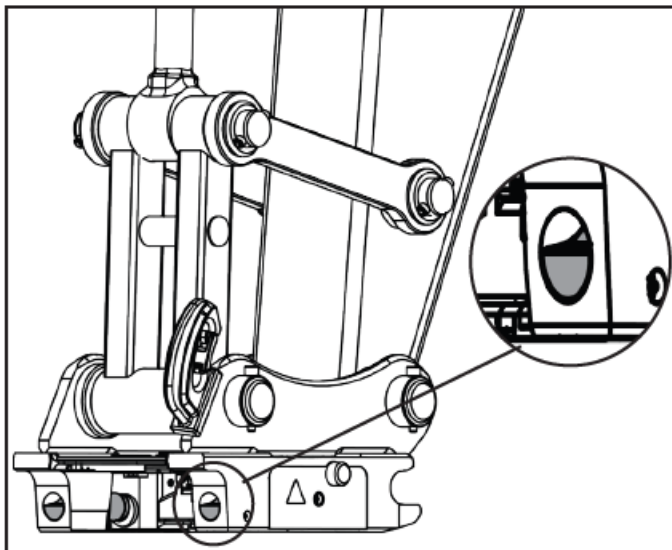

19. Connection of attachments

19.1 - Connection of vertically connected attachments



IMPORTANT TO REMEMBER

- Only attachments with suitable OilQuick attachment frame/ adapter or mechanical attachment frame/ adapter of the same size /model may be connected.
- There is always an element of risk associated with changing attachments.
- No personnel may be within the machine operating area when the attachment is connected to or disconnected from the machine. The attachment can tip and/or fall away during the process.
- The attachment must always be positioned on a horizontal surface that is both hard and stable.
- When opening and locking the quick coupler the machine must be stationary.
- Lock test must always be carried out when connecting and changing an attachment.



NOTE!

Special connection procedures may apply for individual attachments. Refer to the attachment documentation regarding this!



When closing the quick coupler the PressureBoost function automatically boosts the pressure of the locking hydraulics. The operator does not need to perform any additional actions.

NOTE! Where the PressureBoost option is not installed on the machine the driver must increase the pressure in the locking hydraulics by running the bucket cylinder to the limit position, raising the dozer blade or using another similar function.

This section covers connection procedures of attachments that should be connected to the attachment frame/ adapter pin in the horizontal position. Examples of attachments are: Pallet forks, digging bucket, compactor plate, magnet, tiltrotator and grapple.

Procedure

- It is assumed in this section that no attachment is connected and that the quick coupler is open. See "Open quick coupler".
- Check that no-one is within the machine's operating area.
- Check that the quick coupler and attachment frame/adapter of the attachment to be connected are parallel to each other and that the front pin holder of the quick coupler is turned towards the front pin of the attachment frame/-adapter (see images below).
- Check that pins are free of mud and dirt.

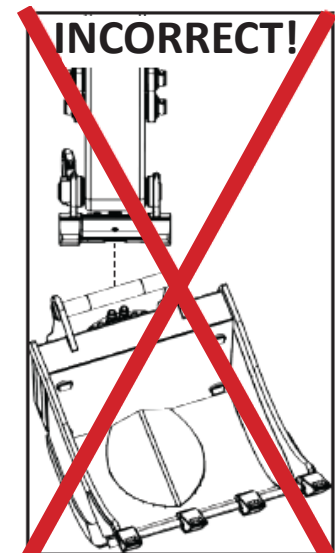
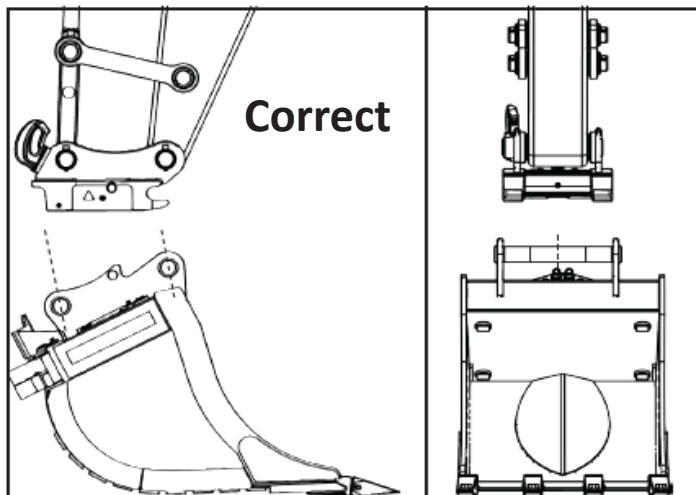

19.1 - Connection of vertically connected attachments - *continued*

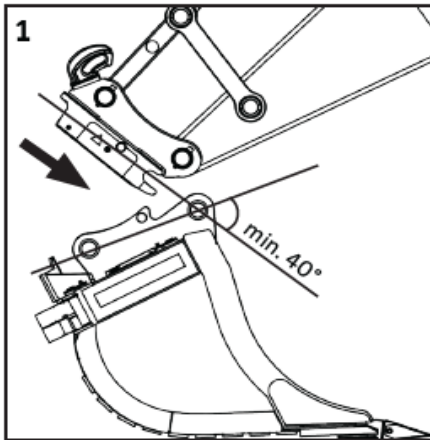

- The quick coupler is open.
- Run out the bucket cylinder to a position where the quick coupler is angled a minimum of 40° to the attachment frame/adapter pins (1).

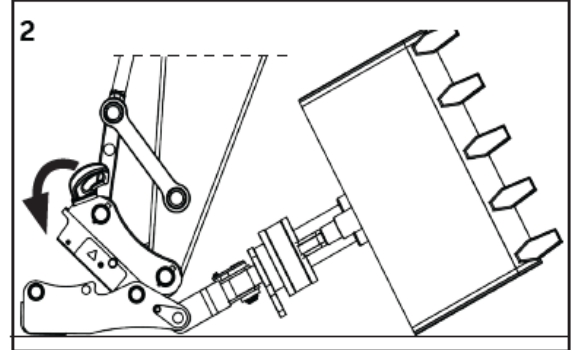

- Hook the front pin holder of the quick coupler around the front pin of the attachment frame/adapter (2).

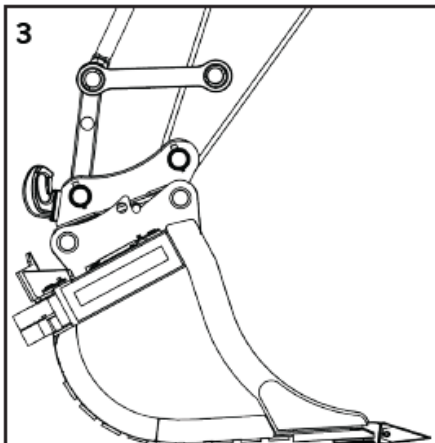

- Run the bucket cylinder out so that the support surface for the rear pin of the quick coupler lies against the rear pin of the attachment frame/adapter (3). **NOTE!** The guide pins on the quick coupler must be guided into the cut-outs correctly on the attachment frame/ adapter's collision protection.

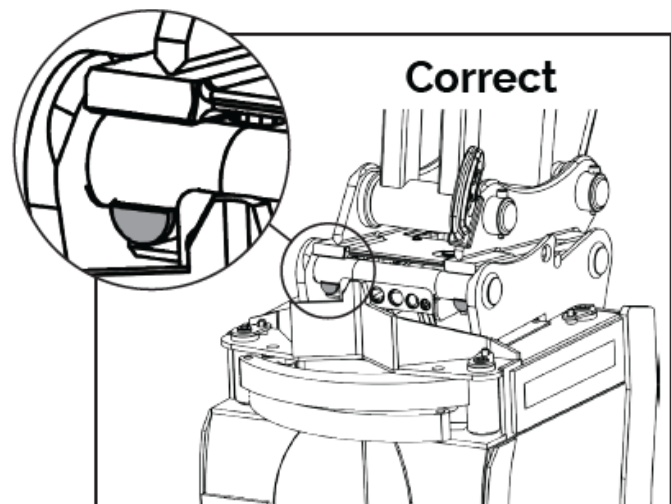

- It is now possible to close the quick coupler to connect the attachment.
- Reference "Description of OQSS control panel", for instructions to lock the quick coupler using the OQSS system.



NOTE!

Perform a lock test according to, see "Description of OQSS control panel", before any work is done.

19.2 - Connection of horizontally connected attachments



IMPORTANT TO REMEMBER

- Only attachments with suitable OilQuick attachment frame/ adapter or mechanical attachment frame/ adapter of the same size /model may be connected.
- There is always an element of risk associated with changing attachments.
- No personnel may be within the machine operating area when the attachment is connected to or disconnected from the machine. The attachment can tip and/or fall away during the process.
- The attachment must always be positioned on a horizontal surface that is both hard and stable.
- When opening and locking the quick coupler the machine must be stationary.
- Lock test must always be carried out when connecting and changing an attachment.



NOTE!

Special connection procedures may apply for individual attachments. Refer to the attachment documentation regarding this!



When closing the quick coupler the PressureBoost function automatically boosts the pressure of the locking hydraulics. The operator does not need to perform any additional actions.

NOTE! Where the PressureBoost option is not installed on the machine the driver must increase the pressure in the locking hydraulics by running the bucket cylinder to the limit position, raising the dozer blade or using another similar function.

This section covers connection procedures of attachments that should be connected to the attachment frame/ adapter pin in the horizontal position. Examples of attachments are: Hydraulic breaker, crusher, grapple and brushes.

Procedure

- It is assumed in this section that no attachment is connected and that the quick coupler is open. See "Open quick coupler".
- Check that no-one is within the machine's operating area.
- Check that the quick coupler and attachment frame/adapter of the attachment to be connected are parallel to each other and that the front pin holder of the quick coupler is turned towards the front pin of the attachment frame/adapter (see images below).
- Check that pins are free of mud and dirt.

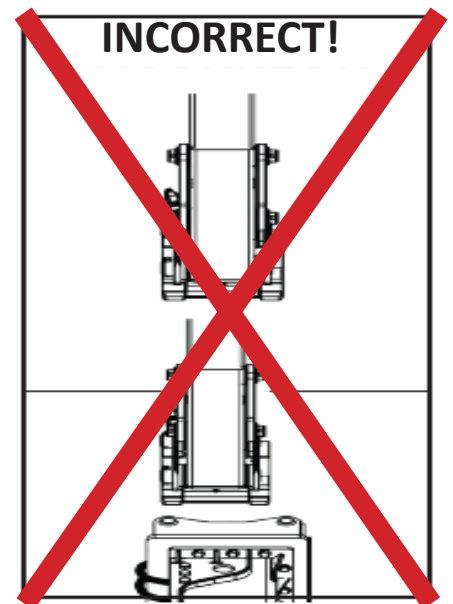
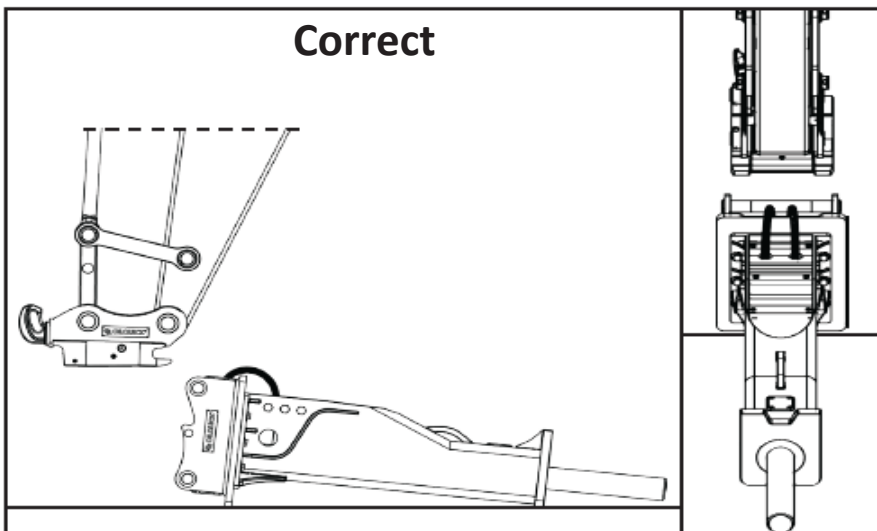

19.2 - Connection of horizontally connected attachments - *continued*

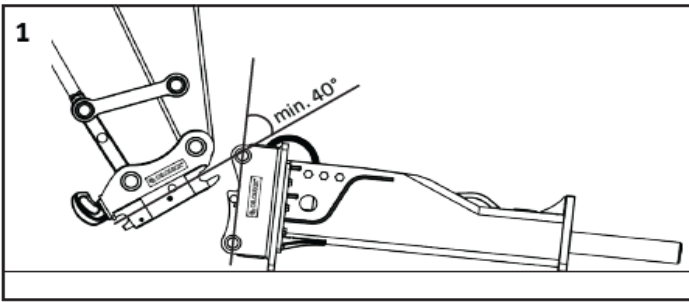

- The quick coupler is open. The warning symbol flashes and the buzzer sounds.
- Run out the bucket cylinder to a position where the quick coupler is angled a minimum of 40° to the attachment frame/adapter pins (1).

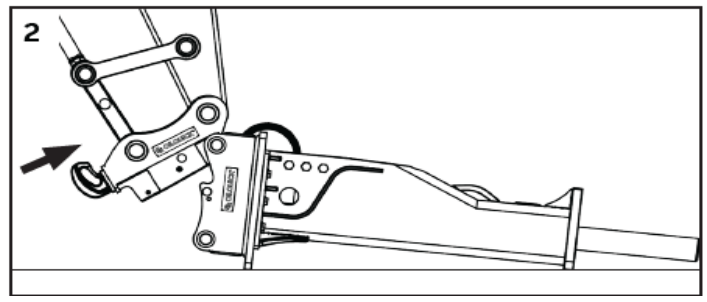

- Hook the front pin holder of the quick coupler around the front pin of the attachment frame/adapter (2).

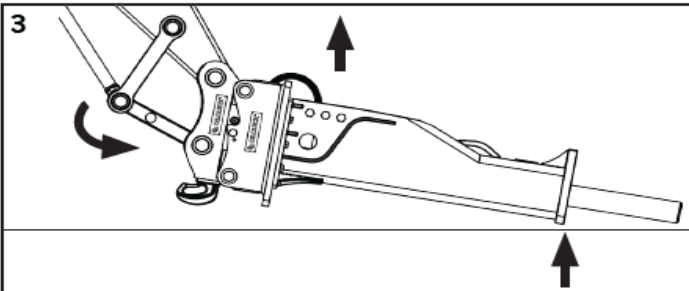

- Lift the attachment so that the outermost part at the attachment frame/adapter just hangs free and run the bucket cylinder out so that the support surface for the rear pin of the quick coupler lies against the rear pin of the attachment frame/adapter (3). **NOTE!** The guide pins on the quick coupler must be guided into the cut-outs correctly on the attachment frame/ adapter's collision protection.

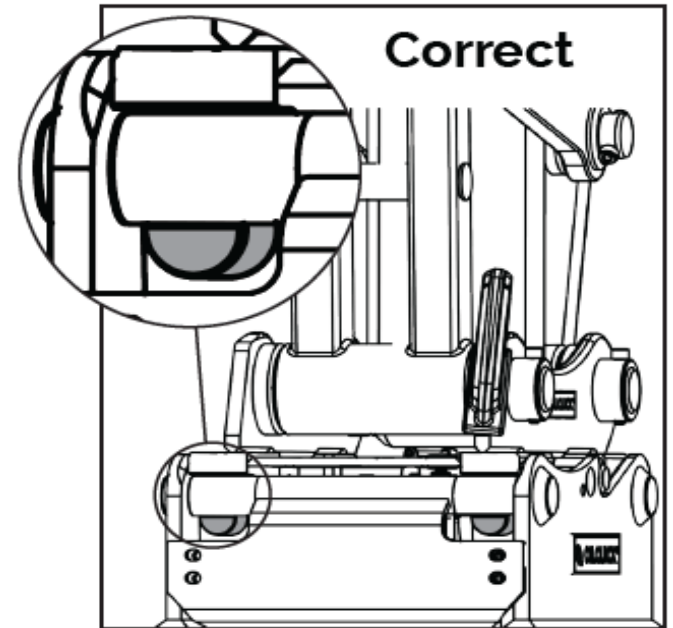

- It is now possible to close the quick coupler to connect the attachment.
- Reference "Description of OQSS control panel" for instructions to lock the quick coupler using the OQSS system.



NOTE!

Perform a lock test according to chapter "Lock test of attachments" before any work is done.

Horizontally connected attachments with a hydraulic function must always be lock tested according to section "Attachments with hydraulic function".

19.3 - Connection of vertically connected attachments with pendulum adapter



IMPORTANT TO REMEMBER

- Only attachments with suitable OilQuick attachment frame/ adapter or mechanical attachment frame/ adapter of the same size /model may be connected.
- There is always an element of risk associated with changing attachments.
- No personnel may be within the machine operating area when the attachment is connected to or disconnected from the machine. The attachment can tip and/or fall away during the process.
- The attachment must always be positioned on a horizontal surface that is both hard and stable.
- When opening and locking the quick coupler the machine must be stationary.
- Lock test must always be carried out when connecting and changing an attachment.



NOTE!

Special connection procedures may apply for individual attachments. Refer to the attachment documentation regarding this!



When closing the quick coupler the PressureBoost function automatically boosts the pressure of the locking hydraulics. The operator does not need to perform any additional actions.

NOTE! Where the PressureBoost option is not installed on the machine the driver must increase the pressure in the locking hydraulics by running the bucket cylinder to the limit position, raising the dozer blade or using another similar function.

This section covers connection procedures of attachments with pendulum adapters where the attachment adapter pins are in vertical position. Examples of attachments with pendulum adapters are: magnet, harvester head and grapple.

Procedure

- It is assumed in this section that no attachment is connected and that the quick coupler is open. See chapter "Open quick coupler".
- Check that no-one is within the machine's operating area.
- Check that the quick coupler and adapter of the attachment to be connected are parallel to each other and that the front pin holder of the quick coupler is turned towards the front pin of the attachment adapter (see images below).
- Check that pins are free of mud and dirt.

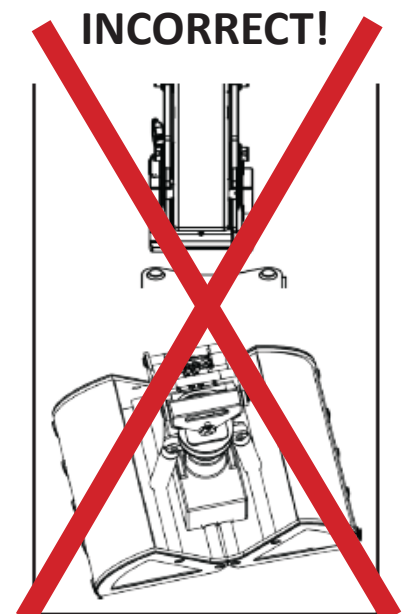
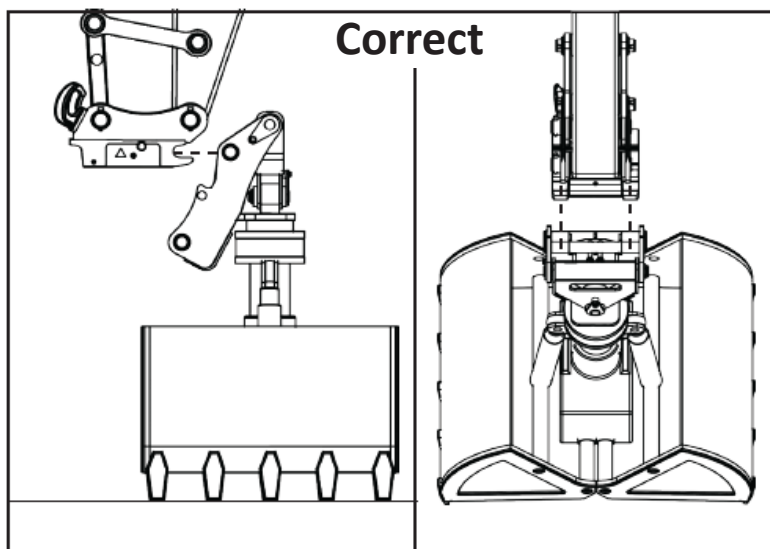

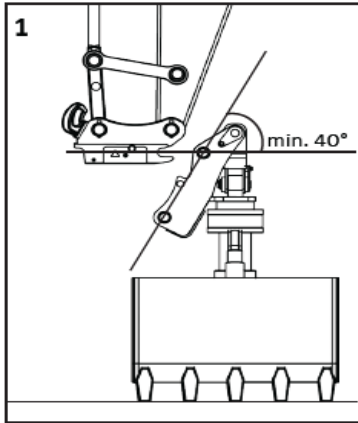

- The quick coupler is open.
- Run out the bucket cylinder to a position where the quick coupler is angled a minimum of 40° to the attachment frame/adapter pins (1).

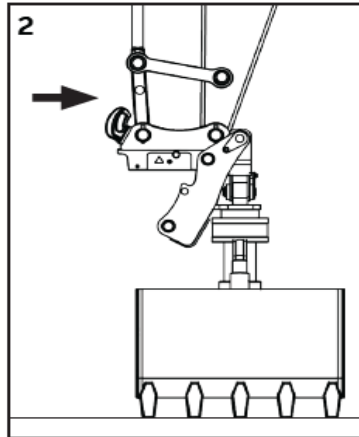

- Hook the front pin holder of the quick coupler around the front pin of the attachment frame/adapter (2).

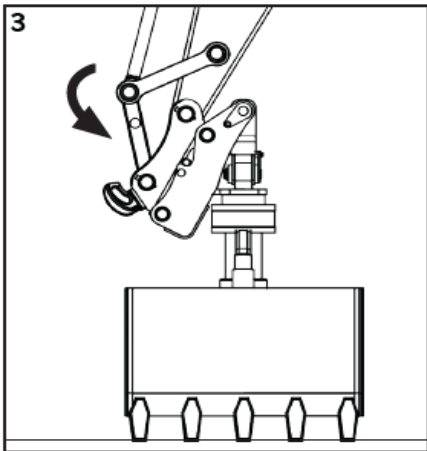

- Run out the bucket cylinder so that the support surface for the rear pin of the quick coupler lies against the rear pin of the attachment adapter (3). **NOTE!** The guide pins on the quick coupler must be guided into the cut-outs correctly on the attachment adapter's collision protection.

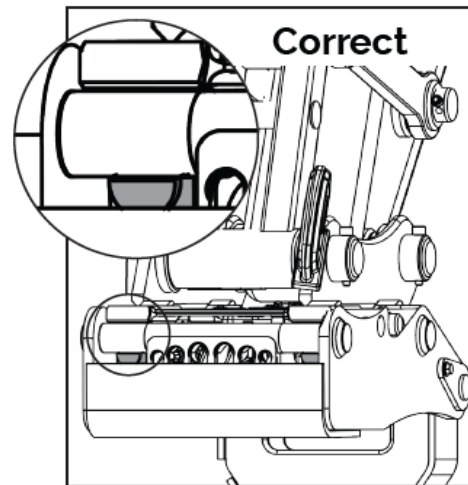

- It is now possible to close the quick coupler to connect the attachment.
- Reference chapter "Description of OQSS control panel" for instructions to lock the quick coupler using the OQSS system.



NOTE!
Perform a lock test according to chapter "Lock test of attachments" before any work is done.

19.4 - Connection of horizontally connected attachments with pendulum adapter



IMPORTANT TO REMEMBER

- Only attachments with suitable OilQuick attachment frame/ adapter or mechanical attachment frame/ adapter of the same size /model may be connected.
- There is always an element of risk associated with changing attachments.
- No personnel may be within the machine operating area when the attachment is connected to or disconnected from the machine. The attachment can tip and/or fall away during the process.
- The attachment must always be positioned on a horizontal surface that is both hard and stable.
- When opening and locking the quick coupler the machine must be stationary.
- Lock test must always be carried out when connecting and changing an attachment.



NOTE!

Special connection procedures may apply for individual attachments. Refer to the attachment documentation regarding this!



When closing the quick coupler the PressureBoost function automatically boosts the pressure of the locking hydraulics. The operator does not need to perform any additional actions.

NOTE! Where the PressureBoost option is not installed on the machine the driver must increase the pressure in the locking hydraulics by running the bucket cylinder to the limit position, raising the dozer blade or using another similar function.

This section covers connection procedures of attachments with pendulum adapters where the attachment adapter pins are in horizontal position. Examples of attachments with pendulum adapters are: magnet, harvester head and grapple.

Procedure

- It is assumed in this section that no attachment is connected and that the quick coupler is open. See chapter "Open quick coupler".
- Check that no-one is within the machine's operating area.
- Check that the quick coupler and adapter of the attachment to be connected are parallel to each other and that the front pin holder of the quick coupler is turned towards the front pin of the attachment adapter (see images below).
- Check that pins are free of mud and dirt.

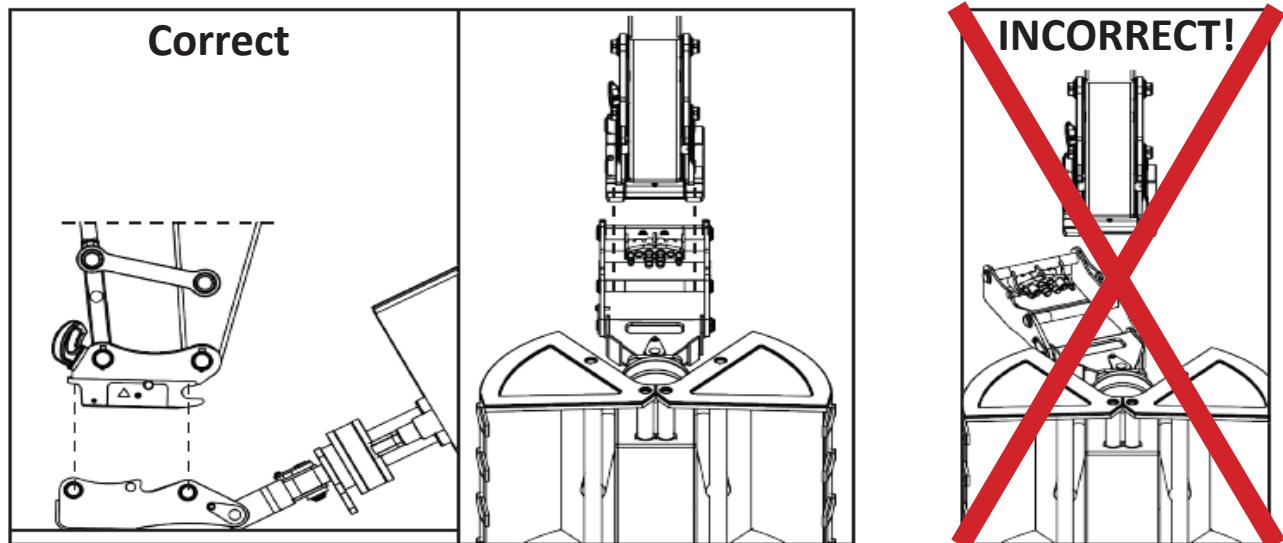

19.4 - Connection of horizontally connected attachments with pendulum adapter - *continued*

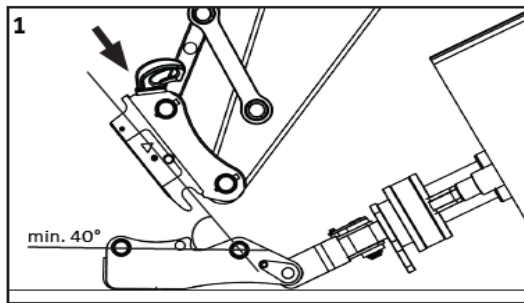

- The quick coupler is open.
- Run out the bucket cylinder to a position where the quick coupler is angled a minimum of 40° to the attachment frame/adapter pins (1).

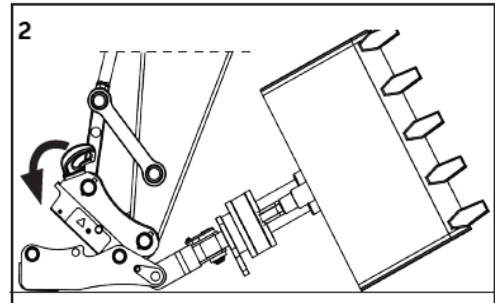

- Hook the front pin holder of the quick coupler around the front pin of the attachment frame/adapter (2).

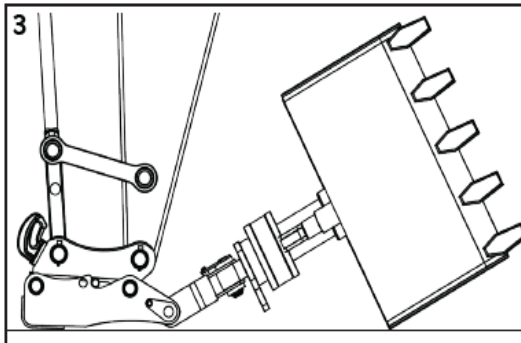

- Run out the bucket cylinder so that the support surface for the rear pin of the quick coupler lies against the rear pin of the attachment adapter (3). **NOTE!** The guide pins on the quick coupler must be guided into the cut-outs correctly on the attachment adapter's collision protection.

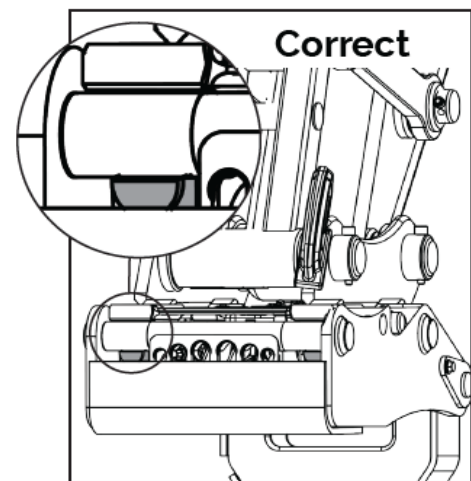

- It is now possible to close the quick coupler to connect the attachment.
- Reference chapter "Description of OQSS control panel" for instructions to lock the quick coupler using the OQSS system.



NOTE!

Perform a lock test according to chapter "Lock test of attachments" before any work is done.

Horizontally connected attachments with a hydraulic function must always be lock tested according to section "Attachments with hydraulic function".

20. Lock test of attachment



THE LOCK TEST MUST ALWAYS BE PERFORMED WHEN ATTACHMENTS ARE CHANGED.

- If connection of the attachment is unsuccessful the reason for this must be determined and corrected before the attachment is reconnected.
- Take great care within the risk area because the attachment may be incorrectly connected and thereby at risk of coming loose.

20.1 - Attachments without hydraulic function

After connecting attachments without a hydraulic function a mechanical lock must be carried out.

Procedure:

- Lift the tool 8" to 12" (20-30 cm) from the ground.
- Press the tool against the ground by breaking against the ground using the machine's bucket cylinder. The force of this should clearly show that the tool is under load and cannot come loose.
- Ready.

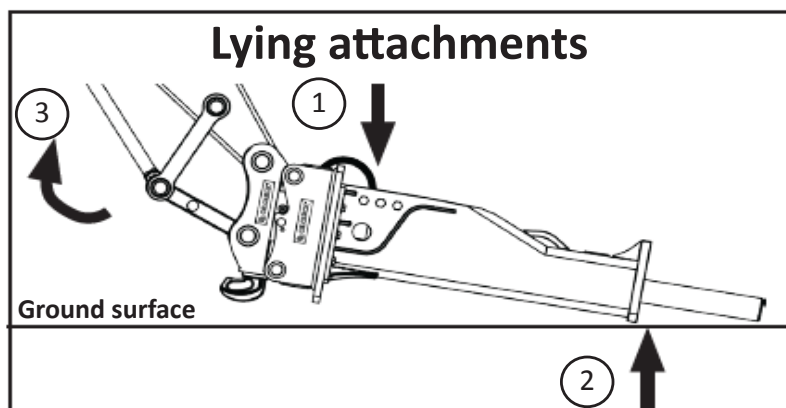
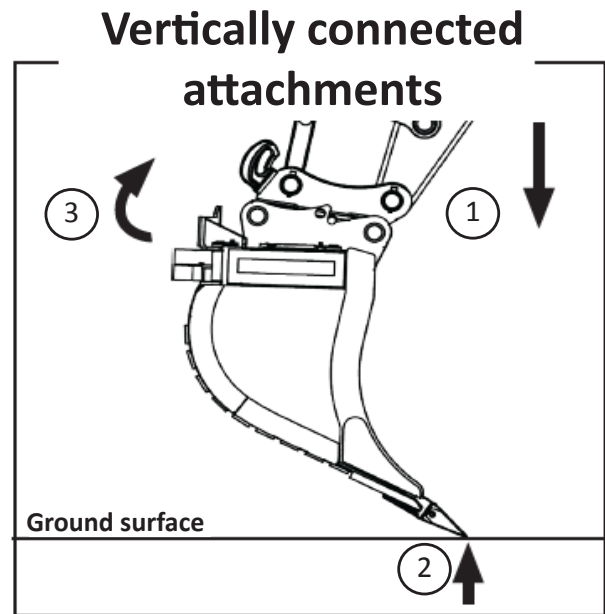
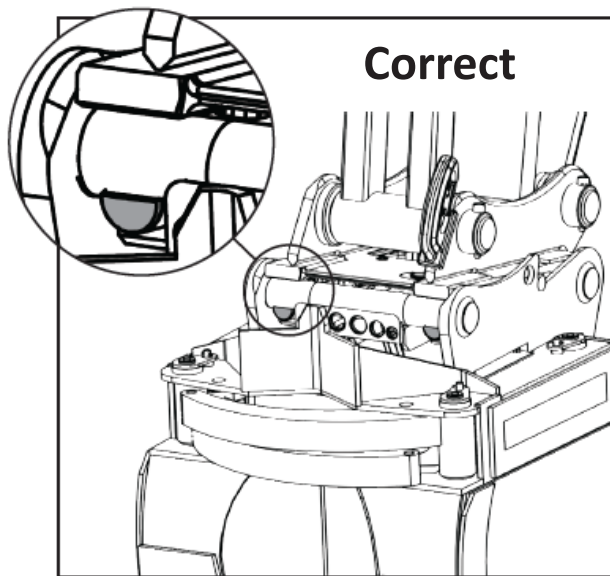

20.2 - Attachments with hydraulic function

After connecting attachments with a hydraulic function a hydraulic lock must be carried out.

Procedure:

- Lift the attachment 8" to 12" (20-30 cm) off the ground.
- Test run a hydraulic function on the tool (1).
- The function must work (2).
- Ready.

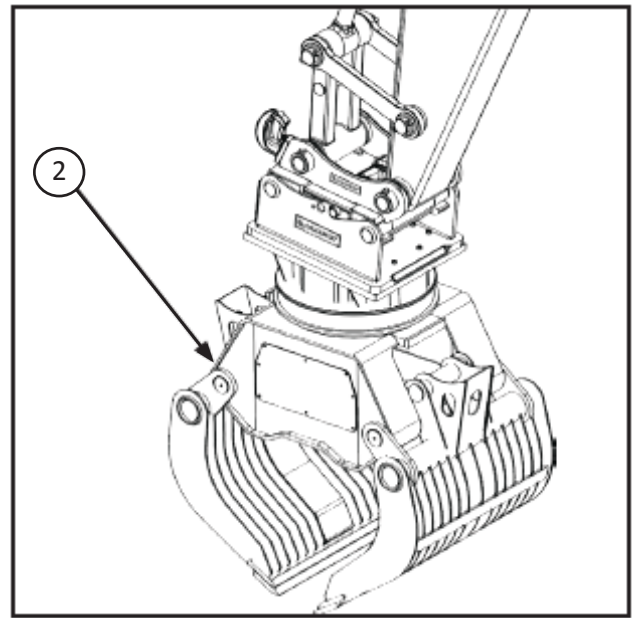
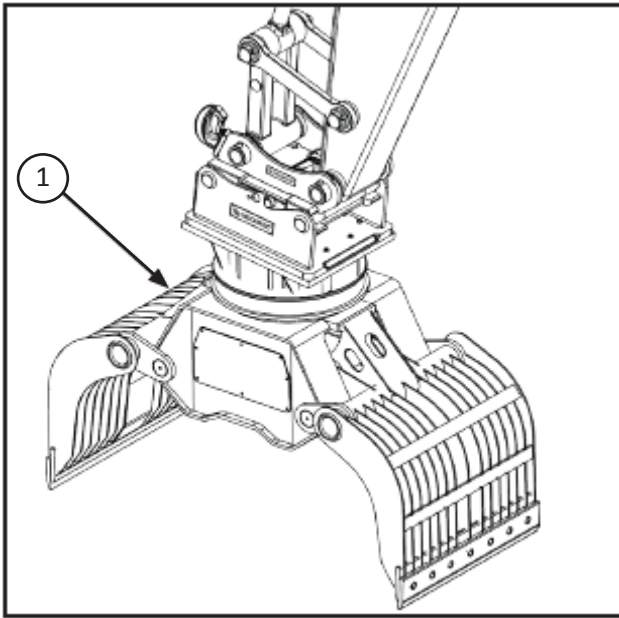

21. Disconnection of attachments

21.1 - Disconnection of vertically connected attachments



IMPORTANT TO REMEMBER

- There is always an element of risk associated with changing attachments.
- No personnel may be within the machine operating area when the attachment is connected to or disconnected from the machine.
- The attachment can tip and/or fall away during the process.
- The attachment must always be positioned on a horizontal surface that is both hard and stable.
- When opening and locking the quick coupler the machine must be stationary.



NOTE!

Special disconnection procedures may apply for individual attachments. Refer to the attachment documentation regarding this!



When opening the quick coupler the PressureBoost function automatically boosts the pressure of the locking hydraulics. The operator does not need to perform any additional actions.

NOTE! Where the PressureBoost option is not installed on the machine the driver must increase the pressure in the locking hydraulics by running the bucket cylinder to the limit position, raising the dozer blade or using another similar function.

21.1 - Disconnection of vertically connected attachments - *continued*

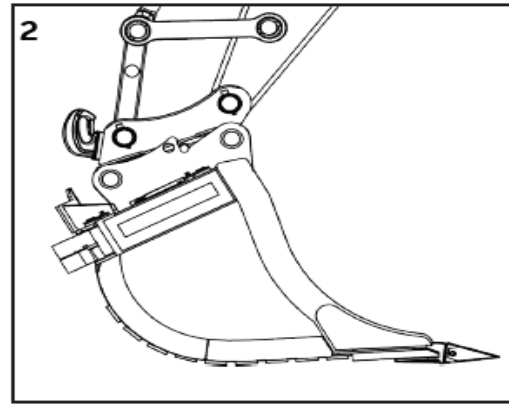
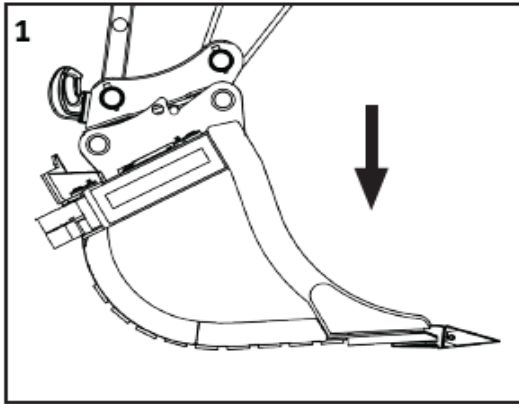

Procedure:

- Check that no-one is within the machine's operating area.
- Position the attachment to be disconnected a little above the ground (1).
- Lower the attachment to the ground so that it just supports itself. The surface must be hard and even (2).
- Alt - curl bucket full in so front pin is cradled in coupler.
- Open the coupler using the OQSS system - reference chapter "Description of OQSS control panel".
- Stall bucket cylinder to build pressure.
- The coupler is now open.
- Carefully lower attachment to the ground
- Run the bucket cylinder in carefully so that the quick coupler leaves the rear pin of the attachment frame/ adapter but still holds the front pin (3). The angle must be a minimum of 40° between the frame/adapter and quick coupler.

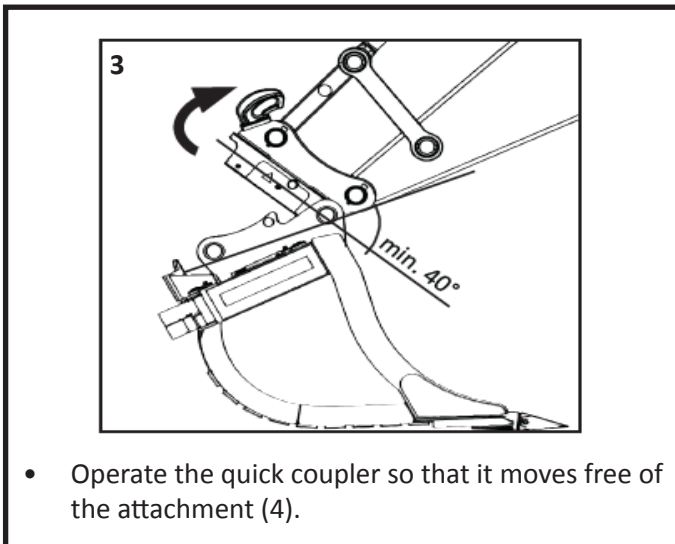

- Operate the quick coupler so that it moves free of the attachment (4).

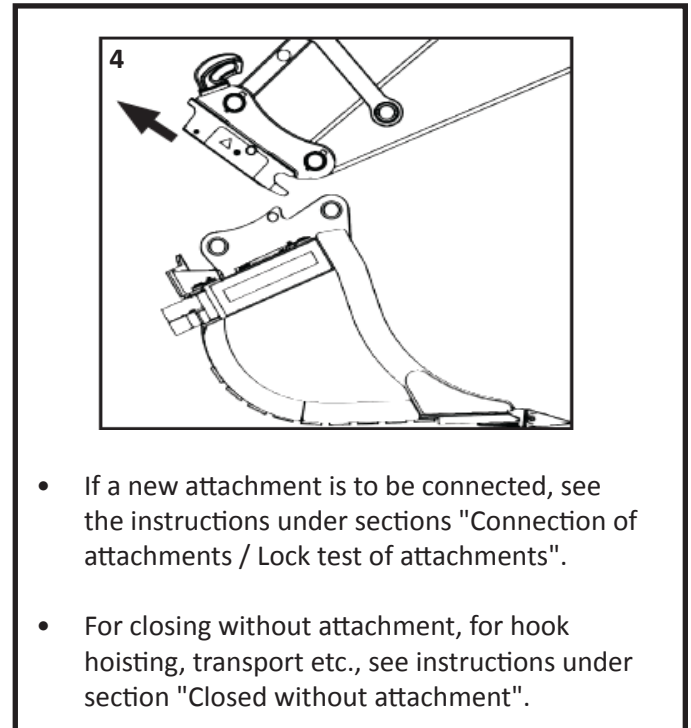

- If a new attachment is to be connected, see the instructions under sections "Connection of attachments / Lock test of attachments".
- For closing without attachment, for hook hoisting, transport etc., see instructions under section "Closed without attachment".

21.2 - Disconnection of horizontally connected attachments



IMPORTANT TO REMEMBER

- There is always an element of risk associated with changing attachments.
- No personnel may be within the machine operating area when the attachment is connected to or disconnected from the machine.
- The attachment can tip and/or fall away during the process.
- The attachment must always be positioned on a horizontal surface that is both hard and stable.
- When opening and locking the quick coupler the machine must be stationary.



NOTE!

Special disconnection procedures may apply for individual attachments. Refer to the attachment documentation regarding this!



When opening the quick coupler the PressureBoost function automatically boosts the pressure of the locking hydraulics. The operator does not need to perform any additional actions.

NOTE! Where the PressureBoost option is not installed on the machine the driver must increase the pressure in the locking hydraulics by running the bucket cylinder to the limit position, raising the dozer blade or using another similar function.

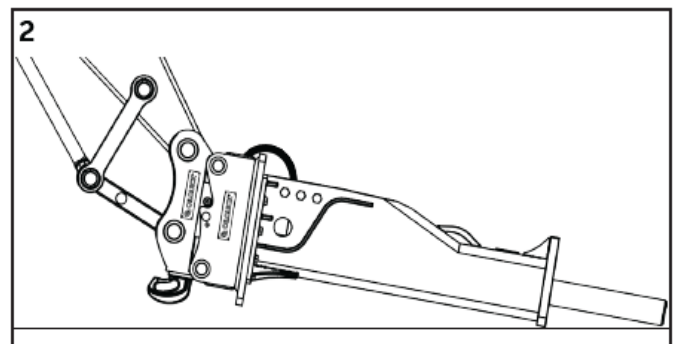
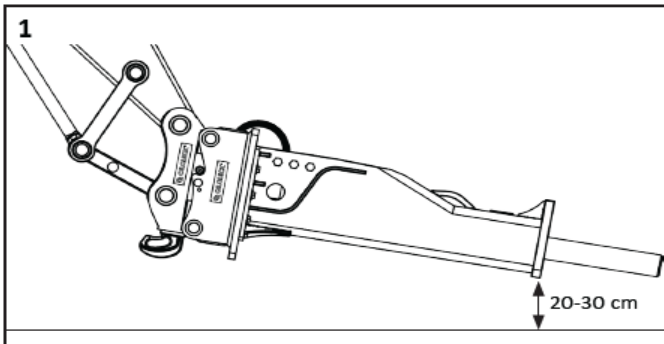

- Check that no-one is within the machine's operating area.
- Alt - curl bucket full in so front pin is cradled in coupler.
- Open the coupler using the OQSS system - reference chapter "Description of OQSS control panel".
- Stall bucket cylinder to build pressure.
- The coupler is now open.
- Run the bucket cylinder in carefully so that the quick coupler leaves the rear pin of the attachment frame/adaptor but still holds the front pin (3). The angle must be a minimum of 40° between the frame/adaptor and quick coupler.
- Position the attachment to be disconnected 20-30 cm above the ground (1).

21.2 - Disconnection of horizontally connected attachments - *continued*

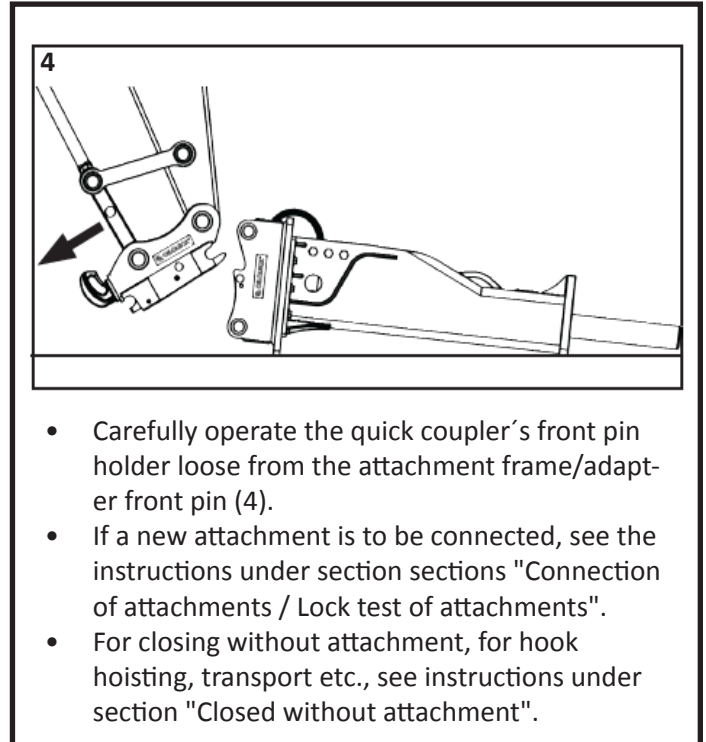
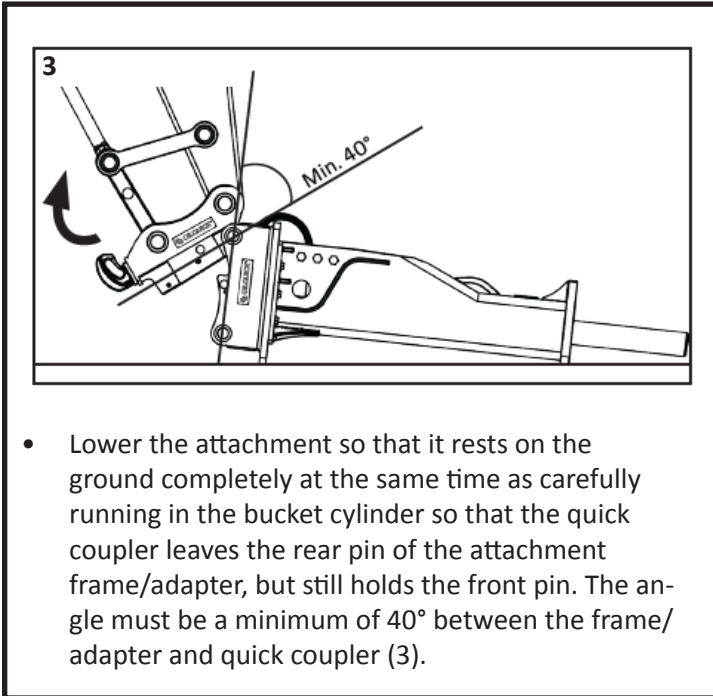

21.3 - Disconnection of vertically connected attachments with pendulum adapter



IMPORTANT TO REMEMBER

- There is always an element of risk associated with changing attachments.
- No personnel may be within the machine operating area when the attachment is connected to or disconnected from the machine.
- The attachment can tip and/or fall away during the process.
- The attachment must always be positioned on a horizontal surface that is both hard and stable.
- When opening and locking the quick coupler the machine must be stationary.



NOTE!
Special disconnection procedures may apply for individual attachments. Refer to the attachment documentation regarding this!



When opening the quick coupler the PressureBoost function automatically boosts the pressure of the locking hydraulics. The operator does not need to perform any additional actions.
NOTE! Where the PressureBoost option is not installed on the machine the driver must increase the pressure in the locking hydraulics by running the bucket cylinder to the limit position, raising the dozer blade or using another similar function.

21.3 - Disconnection of vertically connected attachments with pendulum adapter

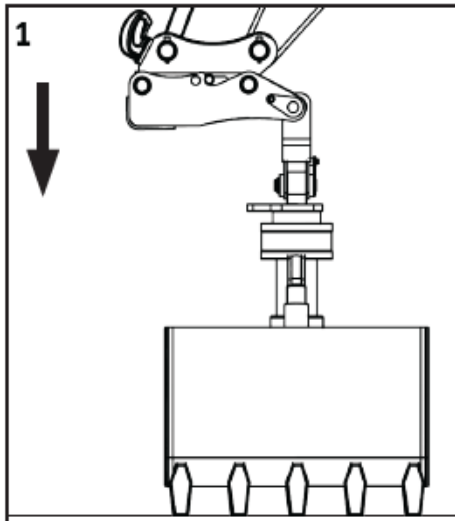

- Check that no-one is within the machine's operating area.
- Lower the attachment to the ground so that it just supports itself. The surface must be hard and even (1).
- Alt - curl bucket full in so front pin is cradled in coupler.
- Open the coupler using the OQSS system - reference chapter "Description of OQSS control panel".
- Stall bucket cylinder to build pressure.
- The coupler is now open.

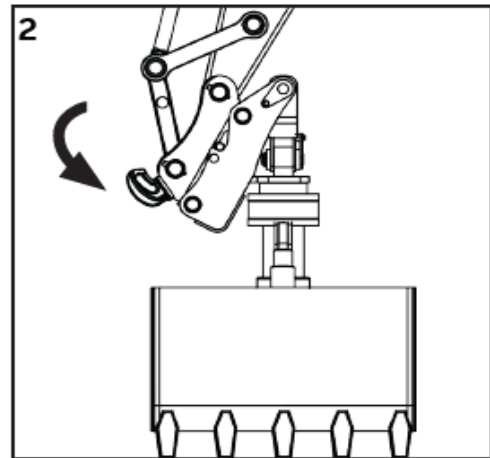

- Run the bucket cylinder in so that the quick coupler leaves the rear pin of the attachment adapter but still holds the front pin. The angle between quick coupler and adapter pins must be 40° minimum (3).

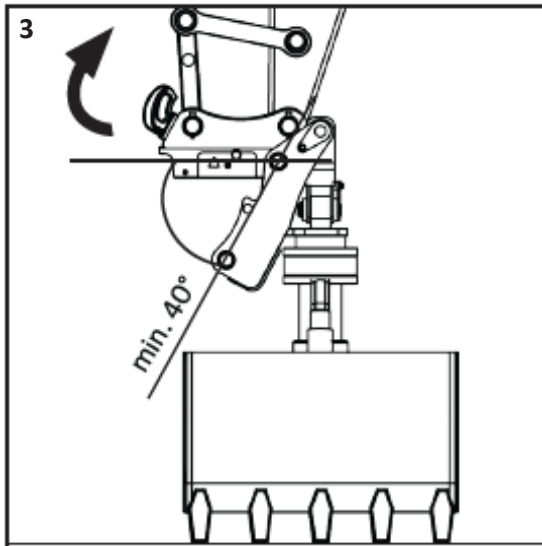

- Carefully operate the quick coupler's front pin holder loose from the attachment front pin (4).

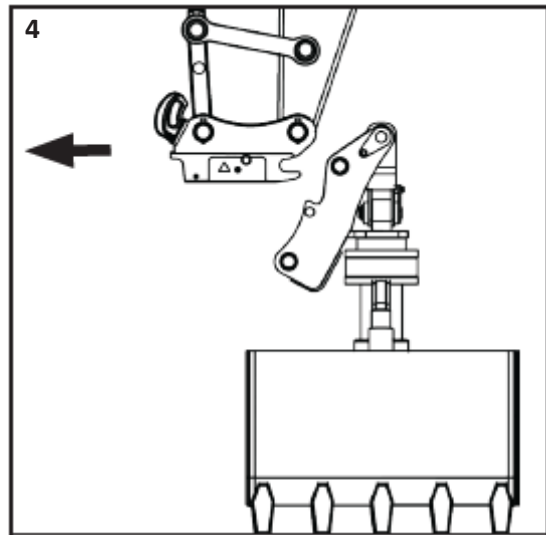

- If a new attachment is to be connected, see the instructions under sections "Connection of attachments / Lock test of attachments".
- For closing without attachment, for hook hoisting, transport etc., see instructions under section "Closed without attachment".

21.4 - Disconnection of horizontally connected attachments with pendulum adapter



IMPORTANT TO REMEMBER

- There is always an element of risk associated with changing attachments.
- No personnel may be within the machine operating area when the attachment is connected to or disconnected from the machine.
- The attachment can tip and/or fall away during the process.
- The attachment must always be positioned on a horizontal surface that is both hard and stable.
- When opening and locking the quick coupler the machine must be stationary.



NOTE!

Special disconnection procedures may apply for individual attachments. Refer to the attachment documentation regarding this!



When opening the quick coupler the PressureBoost function automatically boosts the pressure of the locking hydraulics. The operator does not need to perform any additional actions.

NOTE! Where the PressureBoost option is not installed on the machine the driver must increase the pressure in the locking hydraulics by running the bucket cylinder to the limit position, raising the dozer blade or using another similar function.

1

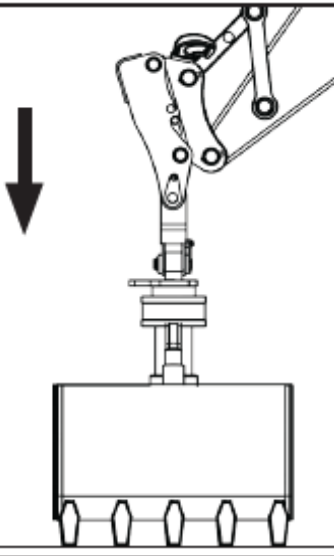

- Check that no-one is within the machine's operating area.
- Lower the attachment to the ground so that it just supports itself. The surface must be hard and even (1).

2

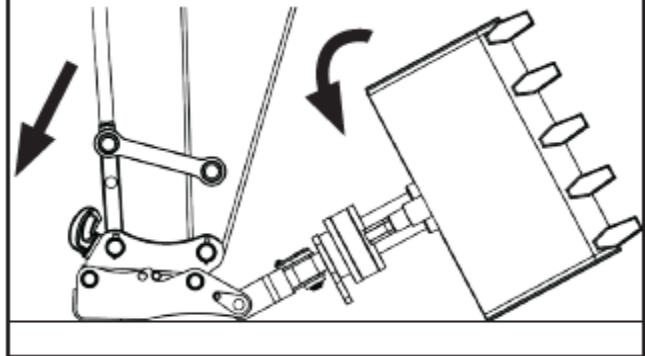

- Run the dipper stick away from the machine and lower it slowly so that the quick coupler attachment adapter and attachment lie against the ground.
- Lower the attachment to the ground so that it just supports itself. The surface must be hard and even (1).
- Alt - curl bucket full in so front pin is cradled in coupler.
- Open the coupler using the OQSS system - reference chapter "Description of OQSS control panel".
- Stall bucket cylinder to build pressure.
- The coupler is now open.

21.4 - Disconnection of horizontally connected attachments with pendulum adapter

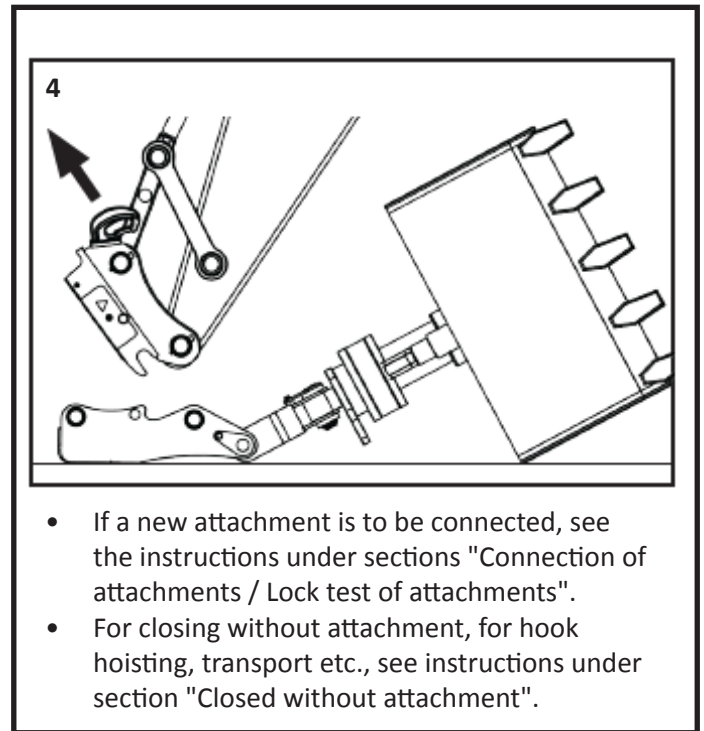
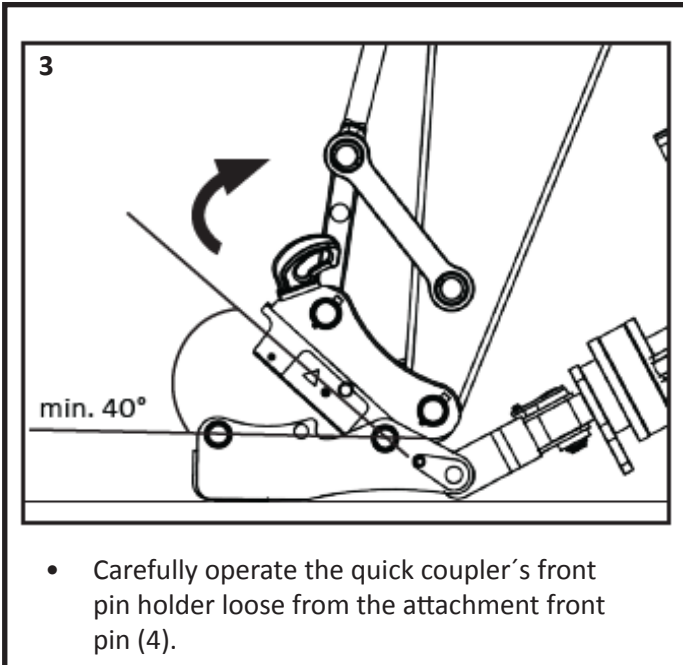

22 - Description of System Faults and Notifications

The OQSS system actively monitors system components for faults and communicates these faults both visually in the control panel and audibly thru the alarm. The system also conveys notifications relating to normal system operation. Faults are categorized in two groups, urgent and non-urgent.

- When an urgent fault is active the coupler icon flashes between red and current state, the status text above the coupler icon flashes between “FAULT” and current state, the fault indicator flashes, and the alarm sounds a slow pulsed tone.
- If there is a critical lock sensor fault or a buzzer fault, the open command is disabled and emergency override must be used to open the coupler, see section 23.
- When a non-urgent fault is active, the fault indicator is shown. The fault can be viewed by pressing the button below the fault indicator.

Description of urgent faults:

1. BUZZER FAULT – Coupler open disabled / check alarm buzzer
2. CRITICAL SENSOR FAULT – Coupler open disabled / check lock sensor
3. PRESSURE SENSOR FAULT – Coupler open disabled / check pressure sensor
4. LOCK VALVE FAULT – Check lock valve
5. LOCK SENSOR FAULT – Check lock sensor

Description of non-urgent faults:

1. RELIEF VALVE 1 FAULT – Check relief valve 1
2. RELIEF VALVE 2 FAULT – Check relief valve 2
3. BOOST VALVE FAULT – Check LS boost valve
4. CAN BUS FAULT – Error detected in CANbus communication
5. OPEN / CLOSE TIMEOUT FAULT – No fault indication on main screen – logged fault
6. LOCK PRESSURE FAULT – Pressure below threshold in lock line for 90+ minutes – logged fault

Description of possible notifications:

1. CONTROL INTERLOCK – If control interlock is enabled, prevents coupler operation when machine control arm is not actuated.
2. GEN INTERLOCK – If gen interlock is enabled, prevents coupler operation when generator for lifting magnet is enabled.

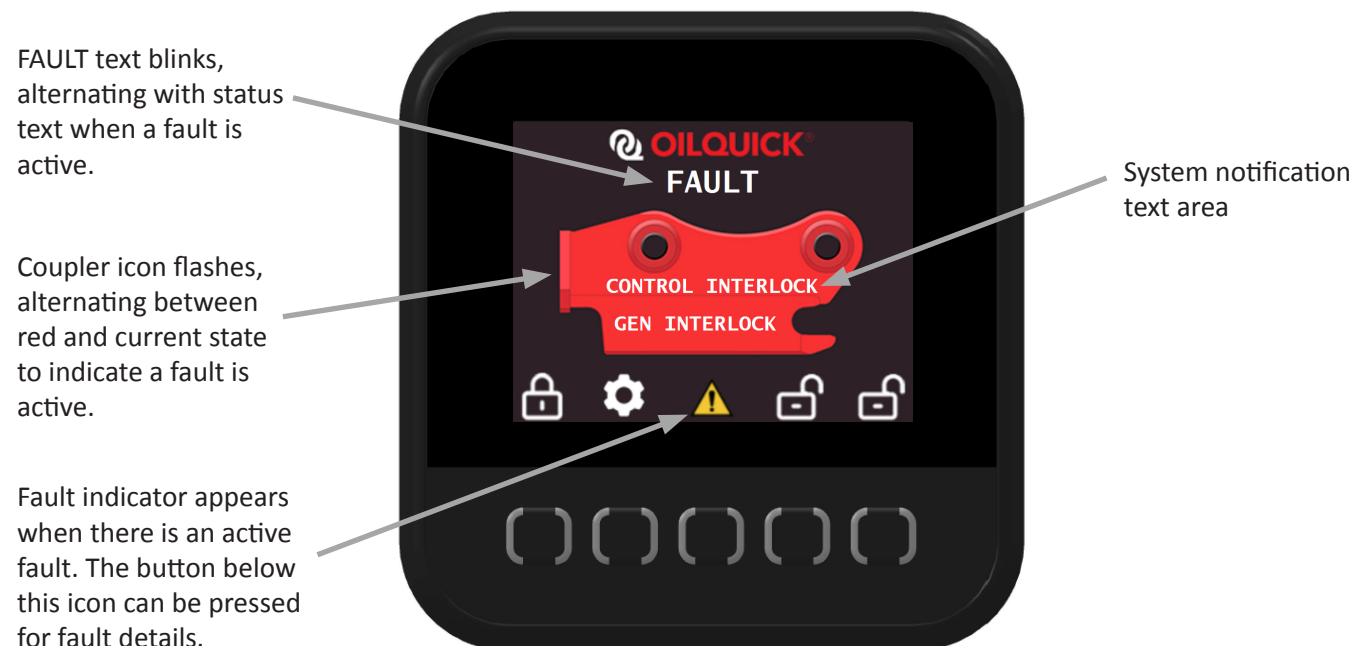

22.1 - Navigation of the Fault Screen

Coupler Open, Fault Active

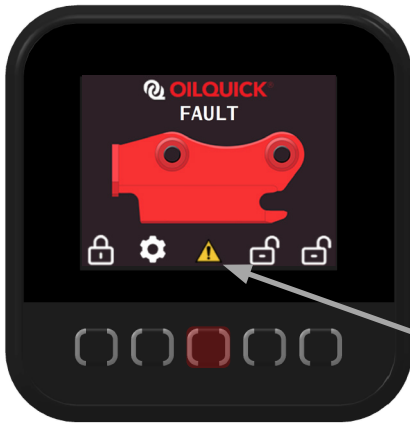

- FAULT indicated
- Press button below fault indicator to enter fault screen

Fault Indicator Icon.

Sample Fault Screen



- Active faults listed
- Press button below fault checkmark to acknowledge fault and return to main screen.

Acknowledge Fault Icon

Sample Fault Screen



- Press button below tech docs icon for additional resources

Tech Docs Icon

Tech Docs QR Code



- Fault QR code can be scanned with your phone for troubleshooting resources
- Press button below back icon to return to fault screen.

23. Emergency Operation

If there is a buzzer fault, critical lock sensor fault, or pressure sensor fault; the coupler open function is disabled. To operate the coupler, emergency operation must be activated. If OVERRIDE PROTECTION is enabled, a password will be required to enter emergency operation.

Main Screen



- From the main screen, press the button below the menu icon.

Menu Icon

Main Menu Screen



- From the main menu screen, use the buttons below the up / down arrows to select "EMERGENCY OPERATION"
- Press the button below the checkmark icon to select "EMERGENCY OPERATION"

23 - Emergency Operation - *continued*

Enter Emergency Screen



- Press button below checkmark icon and input password if prompted to enter EMERGENCY operation
- Press button below X icon to exit EMERGENCY OPERATION
- Press button below back icon to return to the menu.

Main Screen Emergency Operation



- Coupler icon red EMERGENCY OPERATION text flashing, alternating with SENSORS OVERRIDDEN text.
- Alarm sounds continuous tone when coupler is open or opening.
- Alarm changes to pulsed tone when coupler is closing



Emergency Operation is not intended for continuous use!



**Lock test must always be performed after connecting an attachment!
Reference chapter "Lock test of attachments".**

24 - System Menus

The OQSS system menus are used to display system status, for system setup, and for troubleshooting. Within the main menu are the below sub menus:

- System Status
- Emergency Operation
- Troubleshooting
- System Setup
- Fault Log

Main Screen



- Press button below the menu icon to enter the main menu.

Menu Icon

Main Screen



- Use up / down arrow icons and checkmark icon to navigate to desired menu page.
- Press button below tech docs icon for QR link.
- Operation, installation, and parts manuals.

Operation, installation, and parts manuals Icon.

24.1 - System Status Screens

System Status pages show current state of electronically controlled / monitored system components. There are three status screens, all shown below with example status. The buttons between the left / right arrow icons are used to navigate between pages. The coupler can be operated via status pages 1 and 2 to view component status during operation.

Monitored components with descriptions are listed below:

- COUPLER STATUS – Indicated with green, gray, and red boxes around coupler lock/open icons
- CONTROL INTERLOCK – Status of machine control arm signal. ON, OFF, or DISABLED
- GEN INTERLOCK – Status of generator enable signal. ON, OFF, or DISABLED
- LOCK SENSOR 1 – Status of OQSS lock sensor. ON is locked, OFF is not locked
- LOCK SENSOR 2 – Status of OQSS lock sensor. ON is locked, OFF is not locked
- LOCK PRESSURE – Actual pressure in the lock port (not coupler lock pressure)
- SYSTEM VOLTAGE - Actual system supply voltage
- LOCK VALVE – Status of lock valve solenoid. ON, OFF, or FAULT
- PRESSURE BOOST VALVE – Status of LS boost valve solenoid. ON, OFF, FAULT, or DISABLED
- RELIEF VALVE 1 – Status of Relief valve 1 solenoid. ON, OFF, FAULT, or DISABLED
- RELIEF VALVE 2 – Status of Relief valve 2 solenoid. ON, OFF, FAULT, or DISABLED
- ALARM BUZZER – Status of Alarm Buzzer. ON, OFF, or FAULT
- NORMAL LOCK CYCLES – Count of the number of successful lock cycles (coupler locked into tool)
- EMPTY LOCK CYCLES – Count of the number of lock cycles with no tool connection
- EMERGENCY LOCK CYCLES – Count of emergency operation lock cycles
- SYSTEM STARTUPS – Count of system starts



Opening and closing the coupler from status pages 1 and 2:



Opening coupler from “CLOSED NO TOOL” or “LOCKED” status. Press and hold buttons below unlock icons for 8 seconds. Box around open icons shows white until buttons have been held for the required time.

Closing coupler. Press and hold button below lock icon for 8 seconds. Box around lock icon shows white until button has been held for the required time.

24.2 - System Setup Screens

The OQSS system setup interface is intended to be used to configure settings during installation and should only be needed to adjust screen brightness and language during normal operation. All necessary system parameters can be adjusted through this interface to properly set up the OQSS system for your machine. Screen images in this section show default factory settings.

Main Menu



- From the main menu screen select SYSTEM SETUP and press the button below the checkmark icon.
- Password is required to change all parameters but DISPLAY BRIGHTNESS.

Settings Screen



- Page 1/4 – SETTINGS screen is used to select brightness and language and indicates software version.
- **DISPLAY BRIGHTNESS** and **LANGUAGE** can be changed from this screen.
- Available languages are English, Español, and Français
- Use buttons below up / down arrow icons to navigate between items.
- Press button below adjust icon to select variable to adjust.
- The OQSS software P/N and version are listed above the navigation icons.

Lock / Open Settings Screen



- Page 2/4 – LOCK / OPEN SETTINGS screen adjusts system parameters related to coupler opening and closing.
- The default values will work for most installations. Adjustments may be required based on machine performance.
- **ON TIME(s)** is the duration in seconds that the open and close cycles are active. This time may be shortened or extended based on speed of coupler movement during opening and closing.
- **LOCK SENSOR MAINTAIN(ms)** sets the amount of time the coupler must be locked into an attachment after a lock command before the “LOCKED” state can be indicated.
- **OPEN BOOST TIME(s)** sets the duration the load sense valve remains energized after an open cycle.
- **CLOSE BOOST TIME(s)** sets the duration the load sense valve remains energized after a close cycle.
- **VALVE MONITORING (ON/OFF)** enables or disables fault monitoring of system solenoid valves.
- **NOTE** - Valve fault monitoring can be disabled if the valve signal is used as an input to the machine control system or is running a relay.

24.2 - System Setup Screens - *continued*

Option Settings Screen



- Page 3/4 – OPTION SETTINGS screen turns optional settings on and off.
- Correct parameters must be selected based on installation.
- **PRESSURE BOOST (ON / OFF)** enables or disables the feature
- **RELIEF VALVE 1 (ON / OFF)** enables or disables the feature
- **RELIEF VALVE 2 (ON / OFF)** enables or disables the feature
- **CONTROL INTERLOCK (ON / OFF)** enables or disables the feature
- **GEN INTERLOCK (ON / OFF)** enables or disables the feature

Change number in selected digit

Scroll to next digit

Submit password



- Password page will appear after selecting parameter to adjust if not currently in system setup mode.
- Enter password (default is "1111") using button below up arrow icon to change number, and button below right arrow icon to go to the next digit.
- Press button below the checkmark icon to submit the password.

Edit Parameter Screen



- The edit parameter screen allows adjustment of parameters
- Settings that have been changed are saved in memory and will be retained unless changed again.
- Use the buttons below the up / down icons to scroll thru the options (or increase / decrease value in the instance of numeric parameters).
- Press the button below the checkmark icon to save the new setting.

24.2 - System Setup Screens - *continued*

Factory Settings Screen



- Page 4/4 – FACTORY SETTINGS allows customization of owner password and settings store / reset.
- **OVERRIDE PROTECTION** (ON / OFF) enables or disables password protection to enter emergency operation.
- **CUSTOMER PASSWORD** allows the default password (“1111”) to be customized. The process will be explained in the next image.
- **RESTORE ORIGINAL SETTINGS** resets machine parameters to the settings that were created if a factory OilQuick installation was performed.
- **FACTORY RESET** reverts all system settings to the defaults that have been shown in this section (26.3).
- **SAVE SETTINGS** is used by OilQuick personnel when performing a factory installation.

Edit Password Screen



- To edit your password, select “**CUSTOMER PASSWORD**” from the “**FACTORY SETTINGS**” page. You will be prompted to enter your current password (factory default is “1111” if it has not been changed) before the “**EDIT PASSWORD**” screen is displayed.
- Press the button below the up arrow icon to change the number, and the button below the right arrow icon to scroll to the next digit.
- Once your new password is created, write it down and press the button below the checkmark icon. The screen will display “**SUCCESS**” to confirm password change
- New OQSS customer password:



After adjusting any system parameters, proper operation of the OQSS system must be tested to ensure that all settings are appropriate. Couple in and out of attachments multiple times, watching the OQSS control panel for any possible faults. Before returning the machine to service and after testing, view the fault logs to ensure that no faults were caused by the adjustments.

24.3 - Troubleshooting Screens

The OQSS troubleshooting feature allows monitoring and manual control of system components for troubleshooting purposes. The owner password must be entered to manually start or stop components. When system devices are manually overridden in troubleshooting mode the text “FORCE” appears in orange on the upper lefthand corner of the screen. The alarm will sound a pulse every minute while troubleshooting mode is active. The troubleshooting screens mimic the system status screens, with additional functionality shown below.

The troubleshooting mode will timeout and revert to normal operation after thirty minutes, or a power cycle of the OQSS system, and any overridden devices will return to normal state. The password must again be entered if additional troubleshooting is required.



FORCE text signifies that components are in force mode.

Highlighted box around selected component

- Press buttons below up / down arrow icons to navigate to the component to be overridden.
- Selected component will be highlighted.
- Press button below checkmark icon to select component and enter the FORCE page (password may need to be entered for access).

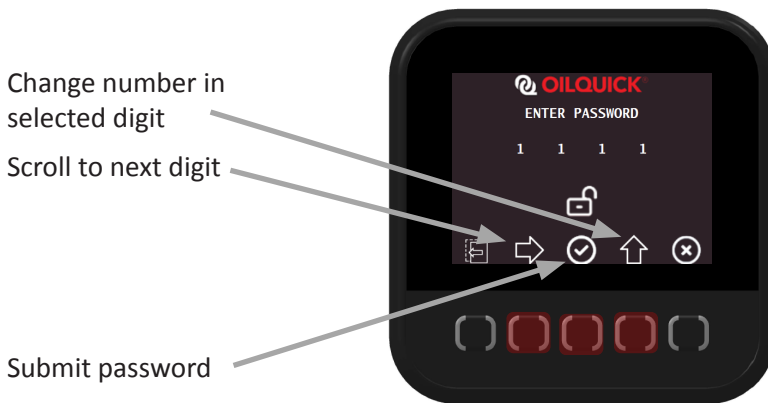

Change number in selected digit

Scroll to next digit

Submit password

- Password page will appear if not currently in troubleshooting mode.
- Enter password (default is “1111”) using button below up arrow icon to change number, and button below right arrow icon to go to the next digit.
- Press button below the checkmark icon to enter the password.

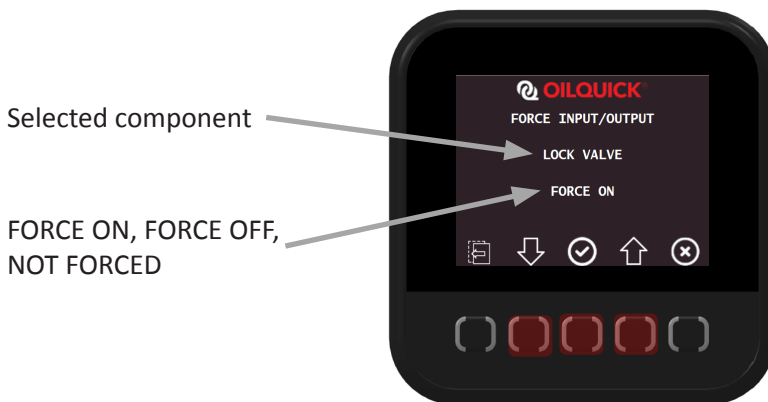

Selected component

FORCE ON, FORCE OFF, NOT FORCED

- Press buttons below up / down arrow icons to select the desired option, “FORCE ON”, “FORCE OFF”, or “NOT FORCED.”
- Press button below checkmark icon to select control option.
- This manually turns electrical components on / off for troubleshooting, for example you can turn a valve signal on while it’s unplugged to check voltage at the plug.

24.4 - Fault Log Screens Screens

The OQSS fault log pages record the most recent 28 faults from the fault list detailed in section 23. Faults are listed in chronological order and identified by startup count. If a fault occurs on the 150th time the system was power cycled, the fault will be numbered 150. In this manner, faults can be tracked historically. The startup count value is listed at the bottom of all four fault log pages. The below image is an example of a fault log page, at system startup 50, with random faults recorded.

Use the buttons below the left / right arrow icons to navigate between fault log pages, and to return to the previous menu,



25 - Use of hoisting hook/ring



The load on the hoisting hook/ring must never exceed the max load of the hook or the machine's lifting capacity. The load must never be greater than the lower of these values.
No attachment or bucket may be attached to the quick coupler during lifting.



Never walk under a suspended load!

The quick coupler can be equipped with a hoisting hook/ring for service lifting at the work place.

Max lifting capacity is limited by two factors:

1. The hoisting hook/ring max load, this is based on the marking of the hook/ring.
2. Machine lifting capacity. This information is provided by the machine's lifting diagram which should be in the cab.

To remember when working on the hoisting hook/ring:

- No tool or bucket may be attached to the quick coupler when working with the hook/ring.
- Max lifting capacity must not be exceeded.
- Approved lifting chains or straps of the correct classification must be used.
- Do not walk under a suspended load.
- The coupler body must be positioned so that the lifting aids do not touch the coupler body. See image.
- Lifting may not occur in a direction that puts a load on the hoisting hook interlock.
- Towing using the hoisting hook/ring is prohibited.
- The hoisting hook/ring must not be subjected to lateral load.

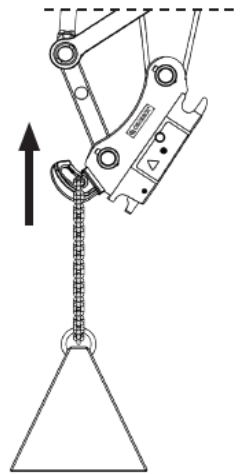

26 - Start and stop of machine at service and maintenance



No one may be near or touching the quick coupler when the machine engine is started or stopped.
Risk of uncontrolled movement of the H-cylinder because of residual pressure in the hydraulic system and changed valve positions.



When working with hydraulic oil, protective gloves must be worn to avoid direct skin contact with the hydraulic oil. There is a risk of skin irritation and allergies.
Be aware of and protect the environment. Collect all waste oil and clean up any spillage.



Cleanliness must be observed when working on hydraulic systems. There is a risk of malfunction if contaminants enter the system.

This section primarily applies to the coming chapters, but also generally.

The hydraulic pressure and electrical system will be affected by the starting and stopping of the machine. This can lead to uncontrolled movements in the locking bolts when the machine engine is started or stopped. Therefore, no one may be near the machine when it is started or stopped.

27 - Inspection and maintenance



Any faults must be corrected immediately. These faults are related to workplace safety.

Regular inspection and maintenance of the OilQuick quick coupler system is essential to retain good function and reliability.

27.1 - Daily inspection

At start of day

- Carry out maintenance procedures according to chapters "Maintenance - OQSS system components / Maintenance of quick coupling".
- Before work with the machine can begin, connection and disconnection of the attachment must be tested in a location where no persons are present.
- Ensure that the hydraulic hoses and hose clamps between the coupling and the dipper stick are not damaged or can be damaged during use. See section "Installation of quick coupler" for examples of correct hose routing.
- Open the quick coupler.
- All acoustic and visual indications via the control panel must function in the intended way.
- The locking bolts must be retracted.
- Close the quick coupler.
- All acoustic and visual indications via the control panel must function in the intended way.
- The locking bolts must be extended.
- Check that shafts and sensors are free of mud and dirt.
- In event of snow and ice, the quick coupler and attachment frame / adapter must be cleaned of ice and snow.
- If necessary, rinse or wipe off mud, slush or anything else that does not belong on the quick coupler or attachment frame / adapter (high pressure washer is not recommended). This is especially important during the winter because it can freeze together and cause damage to piston rods, couplings and other things in the quick coupler.

27 - Inspection and maintenance - *continued*

27.2 - End of day inspection

- Before work with the machine is concluded the attachment must be disconnected and the attachment closed in a location where no persons are present.
- All acoustic and visual indications via the control panel must function in the intended way.
- Check that the quick coupler is free of contaminants such as snow, ice and mud etc. and clean if necessary.
- Checks according to "At start of day".
- Check all screwed joints.
- Check shaft locks.
- Check that the dirt guard functions as intended.
- Check that there is no leakage.
- In event of snow and ice, the quick coupler and attachment frame and adapter must be cleaned of ice and snow.
- If necessary, rinse or wipe off mud, slush or anything else that does not belong on the quick coupler (high pressure washer is not recommended). This is especially important during the winter because it can freeze together and cause damage to piston rods, couplings and other things in the quick coupler.
- Clean the female couplings in the quick coupler.
- Lubricate the locking bolts. There are 4 x grease nipples (2 on OQ 40 and OQ 45) for this purpose "Description of components in OilQuick quick coupler system".
- Side planes on models OQ 40 and OQ 45 are lubricated from the inside with lubricating grease when the H-cylinder is at both its limits positions. A brush that does not lose its bristles can be used as an applicator for this.

NOTE! Grease may only be applied to the inside of the side planes where the H-cylinder runs when the excavator is shut off and the pressure on the operating hydraulics has been relieved!

- Wipe off the tool's quick couplings.

27.3 - Monthly inspection

A more extensive check should be carried out every month.

- Checks according to section "At start of day".
- Check that there is no play in the locking bolts.
- Check that there are no cracks in the quick coupler or attachment frame/adapter.
- Check adjustment and condition of sensor linkage.

Faults detected during inspections must be corrected immediately in order not to impact on the reliability and function of the quick coupler system. Replacement parts can be obtained from the nearest OilQuick representative that also offers servicing.

28 - Maintenance - OQSS system components



NOTE! Never use chemicals or abrasives when cleaning the instrument and components.

All units in the system are either cast or sealed so that the necessary IP classification is maintained. The maintenance by the user is therefore limited to the following periodic checks:

- Wipe the display using a damp cloth. It is very important that the screen light brightly and clearly so that all information reaches the user. If the display becomes damaged, it is essential that the control panel be replaced even if the function is otherwise good.
- Regularly check the cables and pins at the control panel mountings for damage such as wear, open circuits or trapped cables. Any damaged parts must be replaced immediately, even if the function remains good.
- Regularly check the display mounting to ensure the suction mount is secure. A badly mounted display is a safety risk.
- Check that the chassis module, other enclosed units and their cable connections are undamaged.
- Ensure that the cable routing does not cause abrasion and wear on cables.

29 - Maintenance of quick couplings



When working with hydraulic oil, protective gloves must be worn to avoid direct skin contact with the hydraulic oil. There is a risk of skin irritation and allergies.
Be aware of and protect the environment. Collect all waste oil and clean up any spillage.



Cleanliness must be observed when working on hydraulic systems.
There is a risk of malfunction if contaminants enter the system.

Quick couplings that connect the attachment to the machine wear and age with use. If they start to leak they must be maintained or replaced. If there is leakage when the attachment is connected and used then the nose seal is probably damaged and must be replaced. Coupling service instructions are detailed in the remainder of this section.

29.1 - Replacement of nose seal in female coupling

1. Remove the damaged nose seal.
2. Clean the seat for the coupling thoroughly.
3. New nose seal is installed using the special installation tool called a "Pusher".
4. Insert the O-ring, followed by the support ring (black marking upwards) in the pusher pipe, see image (A). **NOTE!** Pusher pipe conical section (upper section) must be turned upwards. For 1/4" and 3/8" female coupling, see point 6 below.



NOTE!

Insert the O-ring first and then the support ring (Does not apply to 1/4" or 3/8" female coupling). The support ring's black marked side must be turned towards the pusher piston.

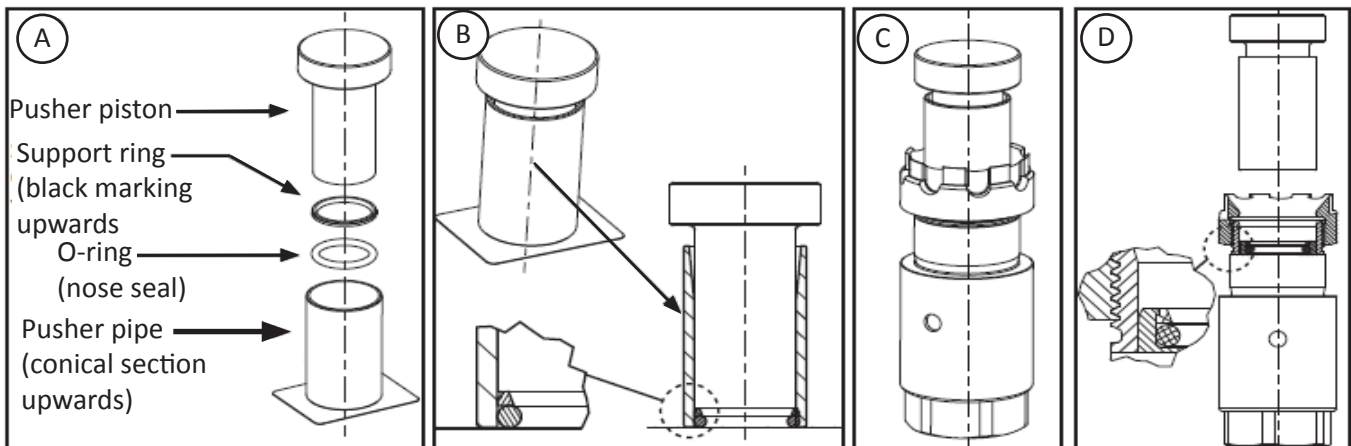

5. Female couplings sized: 1/2", 3/4" and 1": Feed the nose seal into the pusher pipe's lower end by placing the pusher against a table or other flat surface and then pressing the seal down to the bottom position using the pusher piston. See image (B).
6. When loading the pusher when it applies to 1/4" and 3/8" female coupling the support ring and O-ring must be inserted from the other end of the pusher pipe (bottom end) compared with image (A). **NOTE!** The support ring must be inserted first, black marking upwards towards the pusher, followed by the O-ring. Place the pusher against a table or other flat surface and then press the seal down to the bottom position using the pusher piston. See image B).
7. Place the pusher against the female coupling and press the pusher piston firmly. See image (C).
8. Check that the nose seal is correctly installed. See image (D).

29.2 - Replacement of lock ring secured quick couplings

Included parts:

1. Hydraulic connection
2. Quick coupling
3. Dirt guard
4. Guide plate
5. Lock ring
6. Steel washer
7. Seat for quick coupling

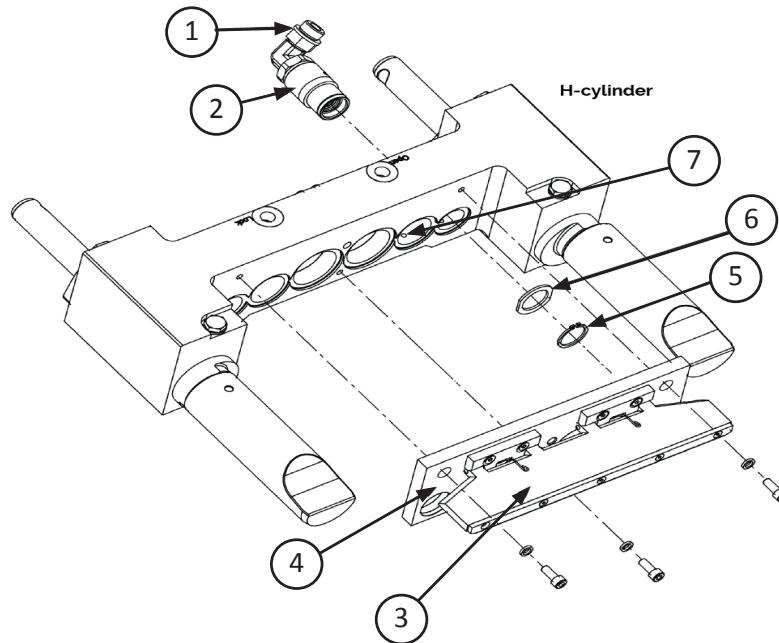

Procedure:

- Shut off the machine and depressurise the operating hydraulics.
- Open the dirt guard (3).
- Unscrew the guide plate (4).
- The lock ring (5) that holds the quick coupling is now accessible. That and the steel washer (6) behind it must be removed and discarded.
- Pull the quick coupling out of the H-cylinder.
- Disconnect the hydraulic connection (hydraulic hose/pipe/adaptor) (1) from the relevant quick coupling (2).
- Discard the quick coupling.
- Reinstall the hydraulic connection on a new quick coupling.
- Before installing a new quick coupling the seat (7) in the H-cylinder must be cleaned and degreased.
- Install new parts and reinstall other relevant parts in reverse order.

29.2 - Replacement of nose nut secured quick couplings

Included parts:

1. Hydraulic connection
2. Quick coupling
3. Dirt guard
4. Guide plate
5. Nose nut
6. Mounting tool (option)
7. Torque wrench (not included)
8. Seat for quick coupling

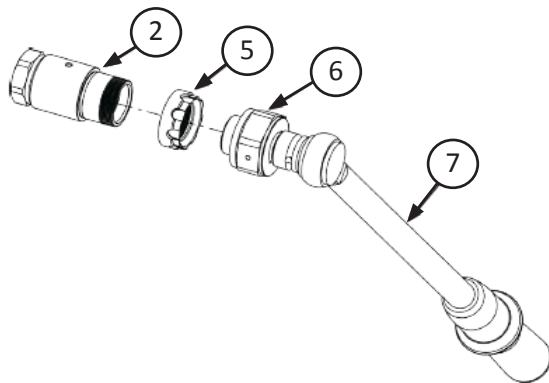

Procedure:

- Shut off the machine and depressurise the operating hydraulics.
- Open the dirt guard (3).
- Unscrew the guide plate (4).
- The nose nut (5) on the quick coupling (2) is now accessible.
- Remove the nose nut (5) using the mounting tool (6) and handle.
- Pull the quick coupling out of the H-cylinder.
- Disconnect the hydraulic connection (hydraulic hose/pipe/adaptor) (1) from the relevant quick coupling (2).
- Discard the quick coupling.
- Before installing a new quick coupling the seat (8) in the H-cylinder must be cleaned and degreased.
- Reinstall the hydraulic connection on a new quick coupling.
- Insert a quick coupling (2) in the H-cylinder seat and hand tighten the nose nut (5).
- Then use the mounting tool (6) and torque wrench (7) to tighten the nose nut on the quick coupling to the stated tightening torque.
- Reinstall other parts in reverse order.

TIGHTENING TORQUE	
3/8"	100±25 Nm
1/2"	175±25 Nm
3/4"	275±25 Nm
1"	375±25 Nm
1 1/2"	575±25 Nm

30 - Plates and decals

Plates and decals below are positioned according to the following explanation. If these are unclear because of damage they must be replaced immediately!



1. Identification plate / ID plate

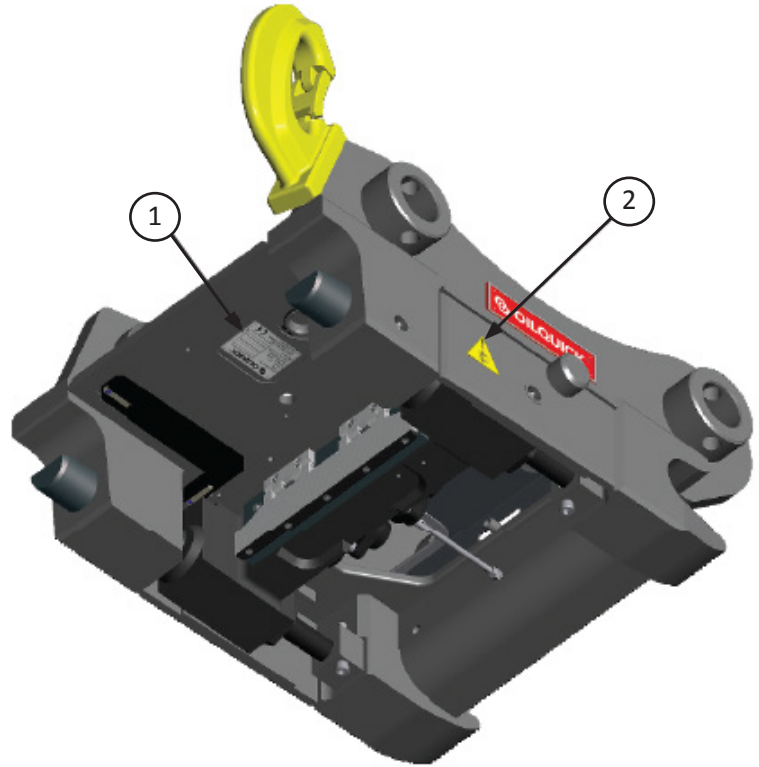

2. Warning decal, risk of crushing

31 - Troubleshooting - Quick coupler

Fault	Possible cause	Action
Quick coupler cannot be closed.	No function in OQSS.	Check according to OQSS troubleshooting.
	The hydraulic pressure in the locking circuit is too low to close the quick coupler.	Check the pressure in the lock circuit. If this is too low, check the lock valve function. If the lock valve is correct the fault is in the machine.
	Dirt guard is not opened and presses against the male coupling. Dirt guard opening bar is missing.	Install new opening bar.
	One or several male couplings have moved out of position and do not fit the female couplings.	Contact OilQuick service.
Quick coupler cannot be opened.	The hydraulic pressure in the locking circuit is too low to open the quick coupler.	Check the pressure in the lock circuit. If this is too low, check the lock valve function. If the lock valve is correct the fault is in the machine.
	One of the two pilot operated check valves in the H-cylinder is defective and will not open.	Contact OilQuick service.
	Pressure relief valve defective.	
Oil leakage from quick coupling when attachment is connected.	Nose seal missing or damaged.	Replace nose seal.
	Leakage due to uneven pressure in the shuttles or low pressure in the machine due to long inactivity.	Check that hydraulic components move at given pressure. Replace nose seal.
Oil leakage from quick coupling when attachment is not connected (female connection)	The quick coupling is dirty or damaged.	Clean or install new quick coupling.
Oil leakage from quick coupling on the attachment (male connection)	The quick coupling is dirty or damaged.	Clean or install new quick coupling.
Attachment hydraulics do not function.	No function in OQSS.	Check according to OQSS troubleshooting.
	The machine does not give the attachment the pressure and/or flow that the attachment requires.	Check the manual for the machine or contact the supplier of the machine.
	Male couplings out of position.	Contact OilQuick service.
	Fault in the attachment's hydraulic and/or electrical systems.	Check the manual for the attachment or contact the supplier of the attachment.
	Correct machine pressure or full machine pressure has not been achieved.	Check that correct pressure has been reached in the machine and attachment.
Attachment's hydraulic and/or electrical systems do not function.	Defective electrical coupling between quick coupler and attachment.	Check the wiring and electrical couplings. Replace or repair defective parts. Refer to the manual for the electrical couplings.

32 - Troubleshooting - OQSS

Fault	Possible cause	Action
Control panel does not start on machine start	Faulty power connection / wiring	Check voltage at keyed power connection with a multi-meter. If machine voltage is present, inspect fuse. Check chassis module power light. If this is lit, the chassis module is receiving power. Inspect wire harness between chassis module and display module.
	Faulty fuse at power connection	Inspect fuse at power connection.
	Faulty OQSS display module	Test power and ground connections to the OQSS display module (test for machine voltage at display connector (pin 7, wire ID 2007), and check continuity between wire harness display plug ground (pin 1. wire ID 2001) and chassis ground connection.
Buzzer fault	Faulty buzzer, Faulty wiring	Enter "Troubleshooting Mode" in OQSS control panel and force buzzer on. If the buzzer is sounding, back probe pin 5 on OQSS display plug (wire ID 2005). Machine voltage should be present. If not, inspect wire 2005 from display module to buzzer. If buzzer does not sound, unplug and test for voltage at buzzer plug pin 2. If machine voltage is present replace buzzer ASSY.
Lock valve fault	Faulty valve cable, Faulty coil	Enter "Troubleshooting Mode" in OQSS control panel and force faulted valve on. Look at lighted plug on affected valve solenoid. If it is lit green, replace coil. If it is not lit unplug and test for voltage at pin 1. If voltage is present replace coil and cable (LED in plug has failed as well as the coil). If there is no voltage, test continuity of valve cable / Harness Control Module and replace as needed.
Boost valve fault		
Relief valve 1 fault		
Relief valve 2 fault		
Open timeout fault	Other component failures, Incorrect settings	Identify whether or not the coupler opened /closed as commanded. If it did, consider adjusting OPEN / CLOSE settings to allow more time before timeout ("ON TIME" must be greater than "TIMEOUT TIME"). If the coupler did not move, inspect for obstructions. Check for other system faults and correct. If there are no other system faults and the coupler did not open / close as commanded refer to section 32 (Troubleshooting - Quick Coupler).
Close timeout fault		
Lock pressure fault	Machine inactivity, Low supply pressure, Incorrect connection	Open "SYSTEM STATUS" and read lock pressure while operating excavator. If it does not rise above 2,200 PSI check connection between pump and OQ lock valve. Verify that the excavator has correct max pressure when a function is stalled. If supply pressure is correct, check to see if the fault is cleared. This fault will appear after thirty minutes of machine operation below 2,200 PSI as a reminder to boost the lock pressure periodically.

32 - Troubleshooting - OQSS - *continued*

Fault	Possible cause	Action
Pressure sensor fault	Faulty pressure sensor, Faulty wiring	Check power and ground at pressure sensor plug (pin 2 power, pin 1 ground). If power and ground are verified to be good, test continuity between pressure sensor cable plug pin 4 (wire ID 1010) and chassis module plug pin 10. If continuity is confirmed, replace pressure sensor. If there is no continuity, determine if faulty wire is in sensor cable or HARNESS CONTROL MODULE. Replace or repair harnesses as needed.
H-Cylinder Sensor Fault	Faulty lock sensor, Faulty wiring	With the machine keyed on and someone in the cab observing the monitor, manually actuate H-cylinder sensor and rear pin sensor by putting a piece of metal against the individual sensors. If both sensors indicate in the cab inspect the interface between sensors and rear pin / H-cylinder. If only one sensor lights, inspect the connection between coupler and chassis module (H-cylinder - wire 1006 - M12 coupler connector pin 4 / rear pin - wire 1005 - M12 coupler connector pin 1). If no indication is shown on the display, check power and ground connections between base of machine and coupler (PWR - wire 1012-4 - M12 coupler connector pin 1 / GRD - wire 1001-4 - M12 coupler connector pin 3).
Rear Pin Sensor Fault		
Can bus fault	Faulty chassis module, Faulty canbus harness, Faulty terminating resistor	Check active faults, if communication with chassis module has failed all valves and sensors will be in fault state. Remove chassis terminating resistor and test resistance on harness between pins A and B. this tests continuity of the CAN wires, along with the cab terminating resistor. If resistance is within spec, test between pins A and B on the removed resistor. Both tests should read 120 ohms. If resistance is within spec, unplug harness from display module and chassis module. Test plug to plug continuity between display plug pin 3 and chassis plug pin 11 (green wire); and display plug pin 4 and chassis plug pin 2 (yellow wire). If harness all wiring tests are within spec, replace the chassis module.

33 - Hydraulic schematic (OQE06747)

REVISIONS				
REV	ECN	DESCRIPTION	DATE	BY
A		ORIGINAL RELEASE	10/23/2024	JPB
B				
C				

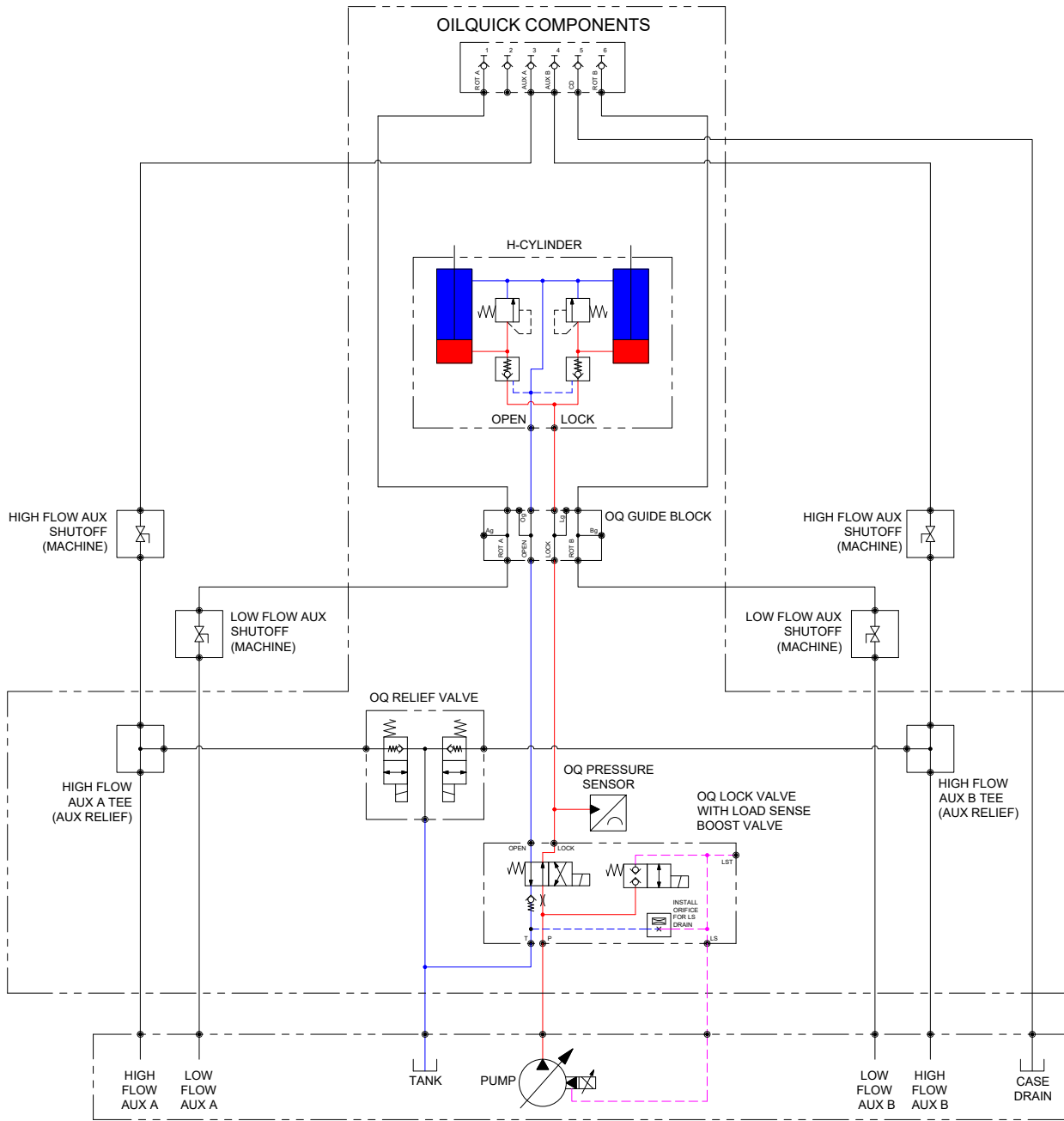

NOTES:

1. COMPLETE OILQUICK SYSTEM INCLUDING BASE MACHINE CONNECTIONS SHOWN
2. COMPONENTS VARY DEPENDANT UPON MACHINE SIZE AND CONFIGURATION
3. TYPICAL COUPLER CONFIGURATION SHOWN. COUPLER CONNECTIONS VARY BASED ON SPECIFIED CONFIGURATION AND COUPLER SIZE
4. LOAD SENSE BOOST NOT TYPICALLY USED IN EXCAVATOR INSTALLATIONS. LS DRAIN PLUG CAN BE REPLACED WITH ORIFICE FOR LS DRAIN
5. HIGH FLOW AUX A / B TEES AND OQ AUX RELIEF VALVE OMITTED IN OQ40 / OQ45

MATERIAL	
UNLESS OTHERWISE SPECIFIED: ALL DIMENSIONS IN INCHES. ALL THREADS TO BE CLASS 2 FIT. ALL MACHINE FINISHES TO BE 320 MICHON MINIMUM. ALL MACHINED EDGES TO BE DEBURRED.	
THIS DRAWING AND THIS DESIGN AND ALL NOVEL AND PATENTABLE FEATURES SEPARATELY OR COLLECTIVELY DISCLOSED AND INCLUDED THEREIN ARE THE PROPERTY OF EXODUS GLOBAL, LLC. AND ARE NOT TO BE COPIED OR TO BE USED, DIRECTLY OR INDIRECTLY, BY ANYBODY WHO IS NOT AN EMPLOYEE OF EXODUS GLOBAL, LLC. WITHOUT THE WRITTEN CONSENT OF SAID COMPANY. THIS DRAWING IS LOANED SUBJECT TO RETURN TO SAID COMPANY UPON THEIR DEMAND. EXODUS GLOBAL, LLC. SUPERIOR, WI USA	
OILQUICK [®]	SUPERIOR, WI USA
TOLERANCES UNLESS OTHERWISE SPECIFIED	DRAWN BY: JPB DATE: 10/23/2024
DECIMAL X.XX ±.030	THIRD ANGLE PROJECTION SHEET 1 OF 1
DECIMAL X.XXX ±.005	DESCRIPTION: HYDRAULIC SCHEMATIC OQSS
FRACTIONAL ±1/16	
ANGULAR ±0.5°	
SCALE: NTS	SIZE PART NO. OQE06747
WEIGHT: LBS	REV. A

34 - Electrical schematic (OQE06358) - sheet 2

IN CAB WIRING

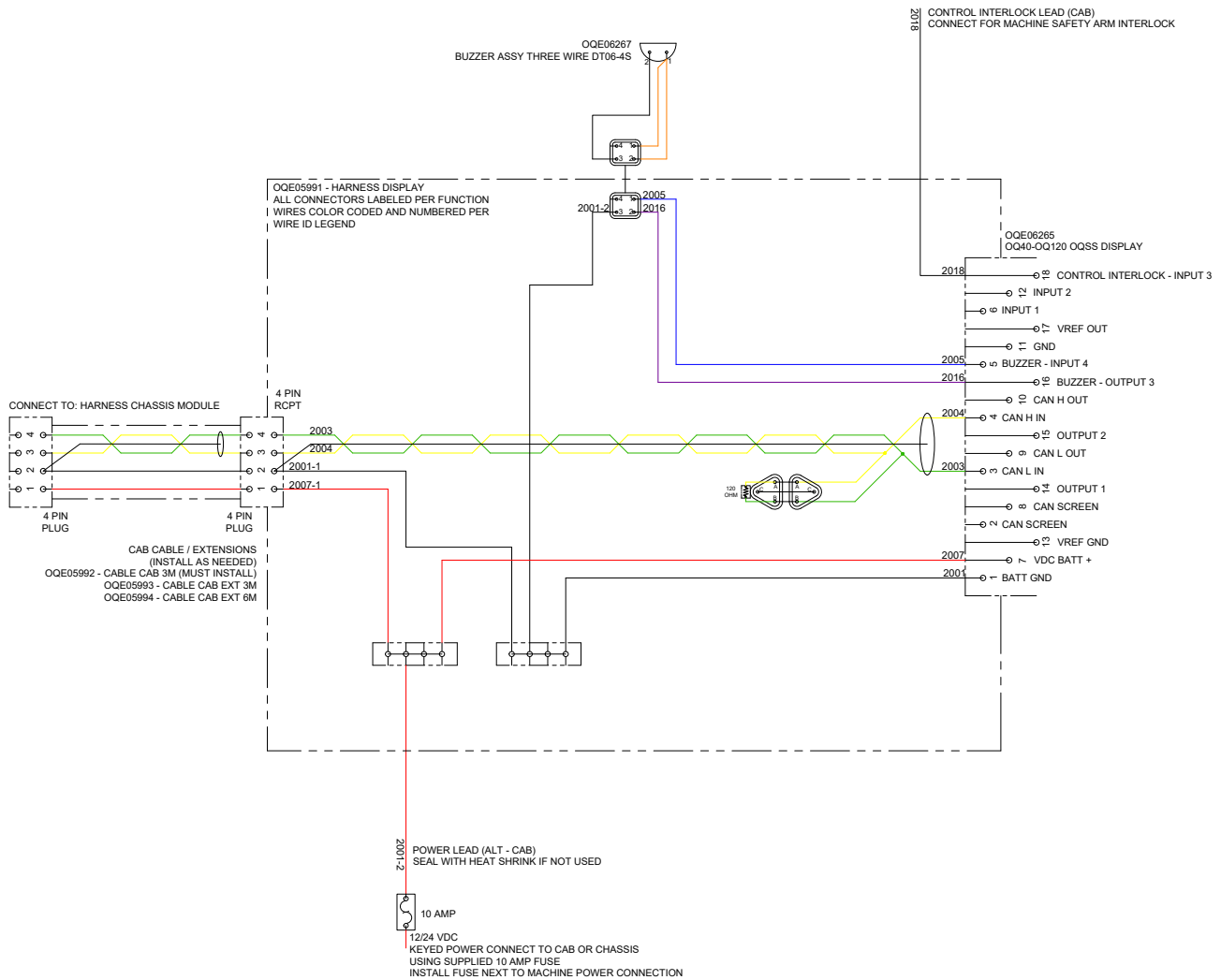

MATERIAL

UNLESS OTHERWISE SPECIFIED:
ALL DIMENSIONS IN INCHES. ALL THREADS TO BE CLASS 2 FIT.
ALL MACHINE FINISHES TO BE 250 MICRON MINIMUM.
ALL MACHINED EDGES TO BE DEBURRED.

THIS DRAWING AND THIS DESIGN AND ALL NOVEL AND PATENTABLE FEATURES SEPARATELY OR COLLECTIVELY DISCLOSED AND INCLUDED THEREIN ARE THE PROPERTY OF EXODUS GLOBAL, LLC AND ARE NOT TO BE COPIED OR TO BE USED, DIRECTLY OR INDIRECTLY, BY ANYBODY WHOEVER WITHOUT THE WRITTEN CONSENT OF SAID COMPANY. THIS DRAWING IS LOANED SUBJECT TO RETURN TO SAID COMPANY UPON THEIR DEMAND. EXODUS GLOBAL, LLC, SUPERIOR, WI USA

OILQUICK SUPERIOR, WI USA

TOLERANCES UNLESS OTHERWISE SPECIFIED: DRAWN BY: JPB DATE: 05/14/2024

DECIMAL X.XX ±.030 THIRD ANGLE PROJECTION SHEET 2 OF 2

DECIMAL X.XXX ±.005 DESCRIPTION: ELECTRICAL SCHEMATIC OQSS CAB CONNECTIONS

FRACTIONAL ±1/16

ANGULAR ±0.5°

SCALE: NTS

WEIGHT: LBS

SIZE PART NO. OQE06358

REV. C

WIRE ID LEGEND			VOLTAGE SPECS			
ID	DESCRIPTION	COLOR	PLUGGED IN		UNPLUGGED	
			ON	OFF	ON	OFF
2001	GROUND	BLACK	0	0	0	0
2003	CAN LO	GREEN	2.5-3.5	N/A	2.5-3.5	N/A
2004	CAN HI	YELLOW	2.5-3.5	N/A	2.5-3.5	N/A
2005	BUZZER INPUT	BLUE / WHITE	+VDC	0	0	0
2007	POWER	RED	+VDC	+VDC	+VDC	+VDC
2016	BUZZER OUTPUT	PURPLE	+VDC	0	+VDC	0
2018	SAFETY GATE	WHITE	+VDC	0	0	0

34.1 - Wiring diagram - (OQE06748) - sheet 1

FULL SYSTEM INSTALLATION SHOWN
 COMPONENTS SUPPLIED AND INSTALLED DEPENDANT UPON COUPLER SIZE AND MACHINE CONFIGURATION

1. HARNESS LABELS DESIGNATE CONNECTION TO BE MADE AT EACH END.
 2. OQE05997 MUST BE CONNECTED TO COUPLER AT STICK TIP.
 3. HARNESS KITS VARY PER COUPLER SIZE AND CONFIGURATION.
 4. "CABLE OQSS SENSOR" (ITEM 14) PRE-INSTALLED ON COUPLER.
 5. HYDRAULIC VALVES SHOWN FOR REFERENCE.
- TYPICAL EXCAVATOR INSTALLATION DOES NOT UTILIZE LS BOOST VALVE.
 - DEPRESSURIZATION VALVE (ITEM 23A/B) NOT USED IN OQ 40 / OQ45 COUPLERS.
 - INSTALL ITEM 19 IN OPEN VALVE SOLENOID PLUGS OF CHASSIS MODULE HARNESS.
 - OQE07037 CABLE DT PL/RCPT VALVE EXT 3M SUPPLIED UPON REQUEST.

REVISIONS				
REV.	ECN	DESCRIPTION	DATE	BY
A		ORIGINAL RELEASE	11/01/2024	JPB
B	5182	ADD ITEMS 24-26 FOR PWR / GRD LEAD OQE05983 / OQE5991 HARNESS UPDATES	03/18/2025	JPB
C	5195	CH OQ 70/55 COUPLER CABLE TO OQE06598	05/08/2025	JPB
D	5218	CHANGE ITEM 14 TO COMMON MOLDED CABLE OBSOLETE OQE05997	01/23/2026	JPB

ITEM	PART#	NAME	QTY	UOM
1	OQE06265	OQ40-OQ120 OQSS DISPLAY	1	EA
2	OQE06266	OQ40-OQ120 OQSS CHASSIS MODULE	1	EA
3	OQ1800514	LOCK SENSOR E-VA	1	EA
4	OQE06267	BUZZER ASSY THREE WIRE DT06-4S	1	EA
5	OQE05983	HARNESS CONTROL MODULE	1	EA
6	OQE05991	HARNESS DISPLAY	1	EA
7	OQE06338	CABLE DT PL/PL PSI SENSOR 4M	1	EA
8	OQE05995	CABLE DT PL/PL VALVE 3M	1-3	EA
9	OQE05992	CABLE DT PL/PL CAB 3M	0-1	EA
10	OQE05993	CABLE DT PL/RCPT CAB EXT 3M (OPTION)	0-2	EA
11	OQE05994	CABLE DT PL/RCPT CAB EXT 6M (OPTION)	1	EA
12	OQE05998	CABLE DT PL/RCPT SENSOR 4M	1-3	EA
13	OQE05999	CABLE DT PL/RCPT SENSOR 10M	1-3	EA
14	OQE07560	CABLE 8-POS FEMALE M12/PL 3M	1	EA
15	30-00864	HEAT SHRINK 22-18 RING TERMINAL, 10-24	2	EA
	30-00865	HEAT SHRINK 22-18 RING TERMINAL, 1/4"	2	EA
	30-00866	HEAT SHRINK 22-18 RING TERMINAL, 3/8"	2	EA
	30-00879	HEAT SHRINK 16-14 RING TERMINAL, 10-24	1	EA
	30-00880	HEAT SHRINK 16-14 RING TERMINAL, 1/4"	1	EA
16	30-00881	HEAT SHRINK 16-14 RING TERMINAL, 3/8"	1	EA
	30-00465	16-14 AWG Blue Crimp Butt Splice	3	EA
17	30-00801	22-18 AWG Red Crimp Butt Splice	3	EA
	30-00862	INLINE FUSE HOLDER MINI	1	EA
18	30-00863	FUSE 10 AMP MINI	1	EA
19	30-00877	CONNECTOR DUST PLUG AT06-2S-SS01	1-3	EA
20	OQE06340	SENSOR PRESSURE 7500 PSI 04MB DT	1	EA
21a	OQ4120613	VALVE - LOCK/OPEN POWERBOOST	1	EA
21b	OQ4129351	LOCK VALVE/POWER BOOST 12V (OQ40 / 45-5)	1	EA
22a	OQ4123124	VALVE - DEPRESSURIZATION 24V DT (OQ60-5 - OQ120)	1	EA
22b	OQ4123125	DEPRESSURIZATION VALVE DOUBLE, 12V (OQ60-5 - OQ120)	1	EA
23	30-00894	CORRUGATED SPLIT LOOM .125" ID	30	FT
24	30-00892	ZIP TIE .098" X 3.9" BLACK	15	EA
25	30-00893	ZIP TIE .098" X 3.9" RED	15	EA
26	OQE07037	CABLE DT PL/RCPT VALVE EXT 3M	0-3	EA

MATERIAL			
UNLESS OTHERWISE SPECIFIED: ALL DIMENSIONS IN INCHES. ALL THREADS TO BE CLASS 2 FIT. ALL MACHINE FINISHES TO BE 250 MICRON MINIMUM. ALL MACHINED EDGES TO BE DEBURRED.			
THIS DRAWING AND THIS DESIGN AND ALL NOVEL AND PATENTABLE FEATURES SEPARATELY OR COLLECTIVELY DISCLOSED AND INCLUDED THEREIN ARE THE PROPERTY OF EXDUS GLOBAL, LLC. AND ARE NOT TO BE COPIED OR TO BE USED, DIRECTLY OR INDIRECTLY, BY ANYBODY WHOSEVER WITHOUT THE WRITTEN CONSENT OF SAID COMPANY. THIS DRAWING IS LOANED SUBJECT TO RETURN TO SAID COMPANY UPON THEIR DEMAND. EXDUS GLOBAL, LLC. SUPERIOR, WI USA			
 OILQUICK ®		SUPERIOR, WI USA	
TOLERANCES UNLESS OTHERWISE SPECIFIED:	DRAWN BY: JPB	DATE: 11/01/2024	
DECIMAL X.XX ±.030	THIRD ANGLE PROJECTION SHEET 1 OF 2		
DECIMAL X.XXX ±.005	DESCRIPTION:		
FRACTIONAL ±1/16	WIRING DIAGRAM OQSS OQ40 - OQ120		
ANGULAR ±0.5°	SCALE: NTS		
WEIGHT: LBS	SIZE A	PART NO. OQE06748	REV. D

34.1 - Wiring diagram - (OQE06748) - sheet 2

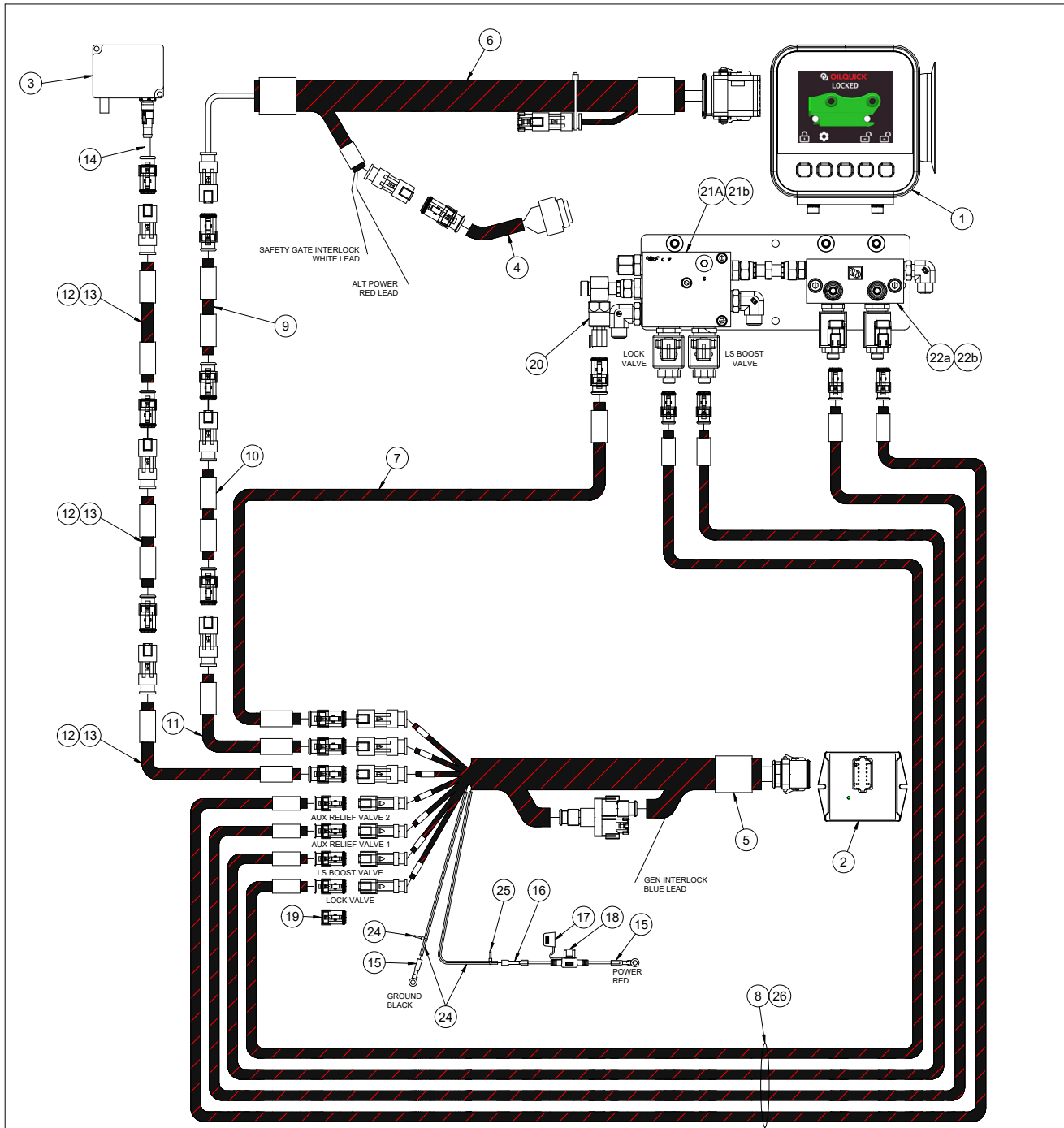

MATERIAL			
UNLESS OTHERWISE SPECIFIED: ALL DIMENSIONS IN INCHES, ALL THREADS TO BE CLASS 2 FIT. ALL MACHINE FINISHES TO BE 320 MICHON MINIMUM. ALL MACHINED EDGES TO BE DEBURRED.			
THIS DRAWING AND THIS DESIGN AND ALL NOVEL AND PATENTABLE FEATURES SEPARATELY OR COLLECTIVELY DISCLOSED AND INCLUDED THEREIN ARE THE PROPERTY OF EXODUS GLOBAL, LLC, AND ARE NOT TO BE COPIED OR TO BE USED, DIRECTLY OR INDIRECTLY, BY ANYBODY WHOMSOEVER WITHOUT THE WRITTEN CONSENT OF SAID COMPANY. THIS DRAWING IS LOANED SUBJECT TO RETURN TO SAID COMPANY UPON THEIR DEMAND. EXODUS GLOBAL, LLC, SUPERIOR, WI, USA			
		SUPERIOR, WI USA	
TOLERANCES UNLESS OTHERWISE SPECIFIED	DRAWN BY: JPB	DATE: 11/01/2024	
DECIMAL X.XXX ±.030	THIRD ANGLE PROJECTION SHEET 2 OF 2		
DECIMAL X.XXX ±.005	DESCRIPTION:		
FRACTIONAL ±1/16	WIRING DIAGRAM OQSS OQ40 - OQ120		
ANGULAR ±0.5°			
SCALE: NTS	SIZE: A	PART NO. OQE06748	REV. D
WEIGHT: LBS			

35 - OilQuick Americas "Approved OEM Locking Hydraulics"

When using an OEM quick coupler locking valve to control an OilQuick quick coupler, it is imperative that the OilQuick Americas "approved locking hydraulics" requirements are met. For the OilQuick system to operate safely, the coupler must always have a direct connection to machine main pump pressure when the coupler is locked into an attachment. This ensures that every time a machine function is operated the quick coupler will be re-pressurized.

A. Approved OEM Locking Hydraulics Requirements

1. The OEM locking valve must have a direct connection to full machine pressure, ideally from both P1 and P2, meeting the requirements in "B" below.
2. The OEM locking valve must connect pump supply to the quick coupler lock line in the de-energized condition.
3. The OEM locking valve must have an unrestricted return line to tank.

B. Testing an OEM quick coupler locking valve for proper operation in conjunction with an OilQuick system.

1. Determine what the machine's maximum operating pressure is.
2. Install a hydraulic pressure gauge using a tee in the quick coupler lock line.
3. With the locking valve in the "lock" condition, operate and stall the below machine functions individually and record the pressure readout shown at the gauge installed in the coupler lock line.
 - i. Bucket curl (in and out).
 - ii. Boom up.
 - iii. Stick out.
 - iv. High flow auxiliary (A and B).
4. If maximum machine operating pressure is recorded in bucket curl (in and out) and at least one other instance above, the OEM locking valve can be used to control the OilQuick quick coupler. If it is not, the OEM lock valve supply connection must be reviewed.
 - i. If the OEM locking valve is connected to only one pump, a shuttle valve may be installed to connect lock valve supply to both machine pumps. Reference OQSS Factory Control Installation Manual section: Installation of shuttle valve on machines with dual pumps. This is the preferred installation and will supply the OilQuick coupler with maximum operating pressure any time a machine function is operated.
 - ii. If maximum machine operating pressure is not measured, it may be possible to increase the OEM locking valve pressure. Reference machine maintenance manual.
 - iii. If the OEM locking valve is supplied only from bucket cylinder extend, it cannot be used with the OQSS system.

35.1 - Considerations when using OilQuick Americas OQSS System

1. Machines without approved OEM locking hydraulics:

A. Standard OQSS System

- i. Operation via the OQSS display module. Quick coupler is operated by pressing buttons on the OilQuick display. The OilQuick locking valve and pressure sensor must be installed to actuate the coupler in this instance.

2. Machines without approved OEM locking hydraulics:

A. Standard OQSS System

- i. Operation via the OQSS display module. Quick coupler is operated by pressing buttons on the OilQuick display. The OEM locking valve may be used and controlled by the OQSS system in this instance. The OilQuick pressure sensor must be installed in the coupler lock line using a tee.

B. Factory Control OQSS System No Valves

- i. Operation via the OEM quick coupler lock switch.
 1. OEM Lock Switch must be accessible for wiring connection and be configured as “hold to run” or “momentary” actuation.
 2. Machine is equipped with approved locking hydraulics.
 3. Machine automatically relieves hi flow AUX circuit pressure during coupler lock and cycles.
 4. Machine automatically strokes pump(s) and verifies that sufficient pressure is achieved upon coupler lock cycle.

C. Factory Control OQSS With Valves

- i. Operation via the OEM lock switch.
 1. OEM Lock Switch must be accessible for wiring connection and be configured as “hold to run” or “momentary” actuation.
 2. Machine is equipped with approved locking hydraulics.
 3. Machine does not automatically relieve hi flow AUX circuit pressure during coupler lock and cycles.
 4. Machine does not verify that sufficient pressure is achieved upon coupler lock cycle.

36 - Lock Sensor Adjustment Check Procedure

1. Couple into attachment, check if green light on sensor is lit.
2. If light is on pull rod out (this will cause fault in control system).
 - A. Light should turn off after 1/8" of rod movement.
 - B. Shims can be inserted between flange nut and sensor bracket to measure actuation.
 - 1/8" SHIM – **LIGHT ON.**
 - 3/16" SHIM – **LIGHT OFF.**

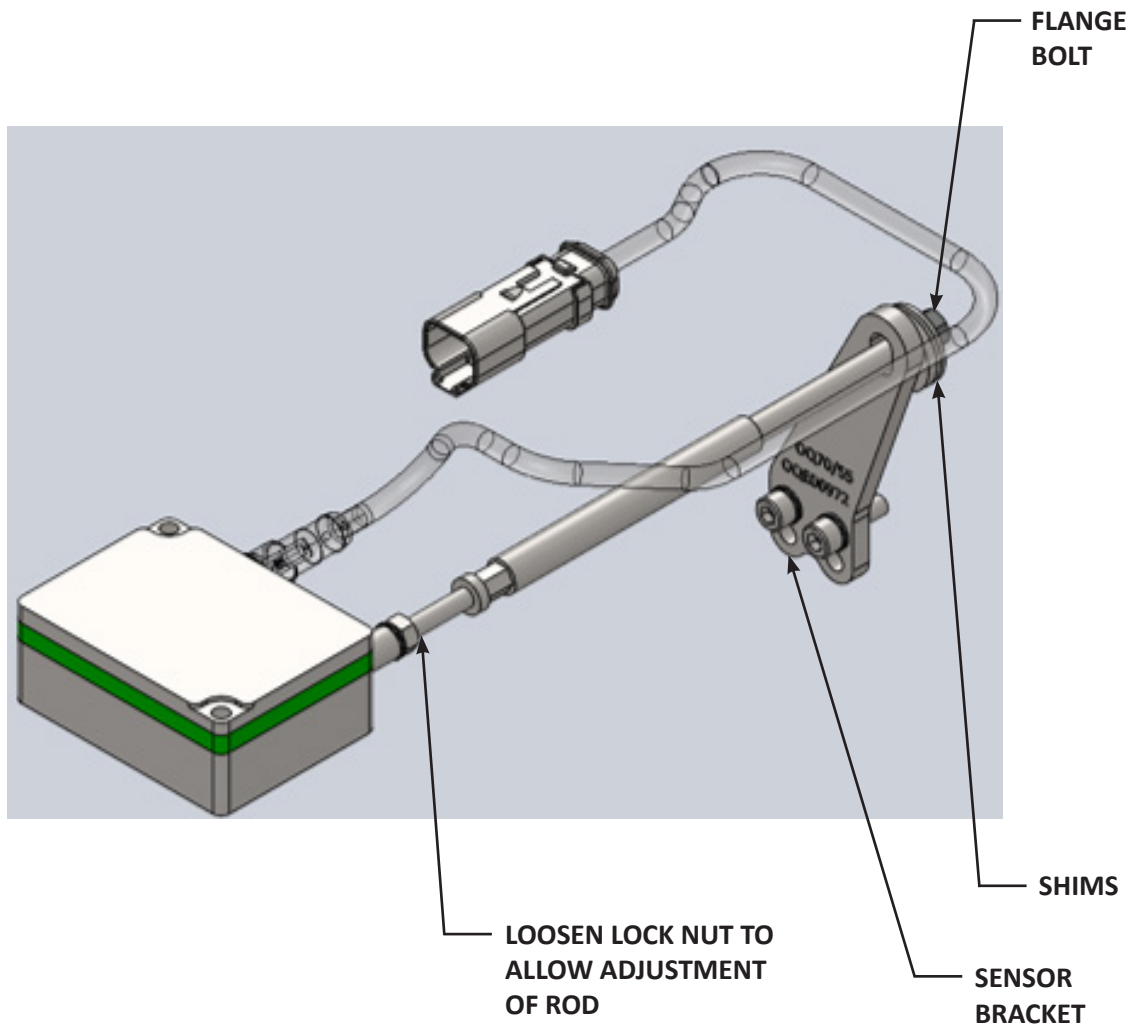

36.1 - Field Sensor Adjustment Check Procedure

1. Remove guard assembly to access lock sensor linkage (if required).
2. Loosen lock nut and thread rod out of sensor until light turns off.
3. Thread rod 2 full turns into sensor and tighten lock nut.
4. Perform adjustment check per above.

37 - OQ Product warranty registration

OilQuick Product Warranty Registration

Thank you for your recent purchase of an OilQuick Automatic Quick Coupler.

Completion of the form below will activate the warranty of the product.

The product warranty for your OilQuick product is dependent on the correct installation on machine and attachment.

By completing the registration form below you are immediately registered as warranty holder for the product.

Unless otherwise agreed, the warranty conditions apply as stated in the product manual. The requested information regarding product type and serial number is stated on the product identification plate.

Information regarding other questions in conjunction with this can be referred to machine dealers or installer.

Purchased from machine dealer: _____

Name and address of end customer: _____

Telephone: _____

Email: _____

Type of OilQuick Coupler: _____

Serial number of coupler: _____

Machine Type: _____

Machine hours at coupler install: _____

Machine weight: _____

Installation Date: _____

Mail the completed warranty form to:

OilQuick Americas
155 Main Street
Superior, Wisconsin 54880

Or complete online via the QR code:

<https://exodusglobal.com/oilquick-americas-warranty>





OILQUICKAMERICAS.COM

+1 262.607.8425

INFO@OILQUICKAMERICAS.COM

155 MAIN STREET

SUPERIOR, WISCONSIN 54880 USA



**OilQuick Americas is part of Exodus Global, a family-owned company
based in Superior, Wisconsin**